

SONY®

Television

Reference Guide

GB

參考指南

CT

BRAVIA

KDL-50W800C / 43W800C

Table of Contents

Safety Information	2
Precautions	5
Parts and Controls	6
Controls and Indicators	6
Inputs and Outputs	7
Using Remote Control	8
Remote Control Parts Description	8
Connecting the TV	10
Installing the TV to the Wall	12
Using your TV's Table-Top Stand as a Wall-Mount Bracket	12
Using an optional Wall-Mount Bracket	17
Troubleshooting	21
Troubles and Solutions	21
Specifications	22

Introduction

Thank you for choosing this Sony product. Before operating the TV, please read this manual thoroughly and retain it for future reference.

Note

- Before operating the TV, please read "Safety Information" (page 2).
- Instructions about "Installing the TV to the Wall" are included within this TV's instructions manual.
- Images and illustrations used in Startup Guide and this manual are for reference only and may differ from actual product appearance.

Location of the identification label

Labels for the TV Model No. and Power Supply rating are located on the rear of the TV.

Labels for the AC adapter Model No. and Serial No. are located on the bottom of the AC adapter.

This television is designed for use in Hong Kong and ensured the usage in Hong Kong only.

Safety Information

WARNING

Batteries must not be exposed to excessive heat such as sunshine, fire or the like.

Installation/Set-up

Install and use the TV set in accordance with the instructions below in order to avoid any risk of fire, electrical shock or damage and/or injuries.

Installation

- The TV set should be installed near an easily accessible AC power outlet (mains socket).
- Place the TV set on a stable, level surface to avoid it from falling down and cause personal injury or damage to the TV.
- Only qualified service personnel should carry out wall installations.
- For safety reasons, it is strongly recommended that you use Sony accessories, including:
 - Wall-Mount Bracket (Supplied)
 - Wall-Mount Bracket SU-WL450
- Be sure to use the screws supplied with the Wall-Mount Bracket when attaching the Mounting Hooks (Stand)/Wall-Mount Bracket to the TV set. The supplied screws are designed as indicated by illustration when measured from the attaching surface of the Mounting Hooks (Stand)/Wall-Mount Bracket. The diameter and length of the screws differ depending on the Wall-Mount Bracket model.

Use of screws other than those supplied may result in internal damage to the TV set or cause it to fall, etc.

- Wall-Mount Bracket (Supplied)

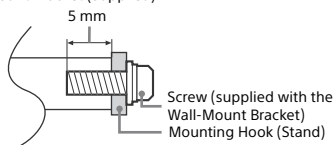

- Wall-Mount Bracket SU-WL450

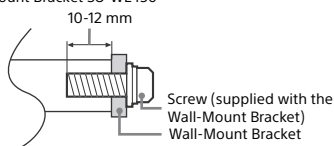

Transporting

- Before transporting the TV set, disconnect all cables.
- Two or three people are needed to transport a large TV set.
- When transporting the TV set by hand, hold it as shown below. Do not put stress on the LCD panel and the frame around the screen.

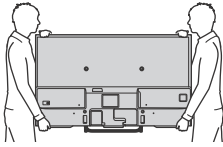

- When transporting the TV set, do not subject it to jolts or excessive vibration.
- When transporting the TV set for repairs or when moving, pack it using the original carton and packing material.

Ventilation

- Never cover the ventilation holes or insert anything in the cabinet.
- Leave space around the TV set as shown below.
- It is strongly recommended that you use a Sony Wall-Mount Bracket in order to provide adequate air circulation.

Installed on the wall

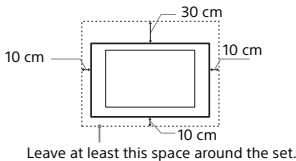

Installed with stand

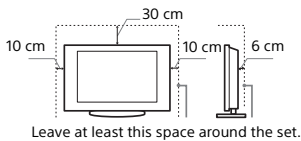

- To ensure proper ventilation and prevent the collection of dirt or dust:
 - Do not lay the TV set flat, install upside down, backwards, or sideways.
 - Do not place the TV set on a shelf, rug, bed or in a closet.
 - Do not cover the TV set with a cloth, such as curtains, or items such as newspapers, etc.
 - Do not install the TV set as shown below.

Air circulation is blocked.

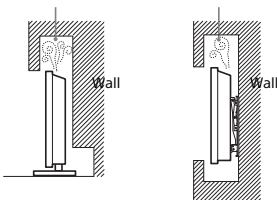

AC power cord (mains lead)

Handle the AC power cord (mains lead) and outlet (mains socket) as follows in order to avoid any risk of fire, electrical shock or damage and/or injuries:

- Use only Sony supplied AC power cords (mains lead), not those of other brands.
- Insert the plug fully into the AC power outlet (mains socket).
- Operate the TV set on a 220-240 V AC supply only.
- When wiring cables, be sure to unplug the AC power cord (mains lead) for your safety and take care not to catch your feet on the cables.

- Disconnect the AC power cord (mains lead) from the AC power outlet (mains socket) before working on or moving the TV set.
- Keep the AC power cord (mains lead) away from heat sources.
- Unplug the AC power plug (mains plug) and clean it regularly. If the plug is covered with dust and it picks up moisture, its insulation may deteriorate, which could result in a fire.

Note

- Do not use the supplied AC power cord (mains lead) on any other equipment.
- Do not pinch, bend, or twist the AC power cord (mains lead) excessively. The core conductors may be exposed or broken.
- Do not modify the AC power cord (mains lead).
- Do not put anything heavy on the AC power cord (mains lead).
- Do not pull on the AC power cord (mains lead) itself when disconnecting the AC power cord (mains lead).
- Do not connect too many appliances to the same AC power outlet (mains socket).
- Do not use a poor fitting AC power outlet (mains socket).

NOTE ON AC ADAPTER

Warning

To reduce the risk of fire or electric shock, do not expose this apparatus to rain or moisture. To prevent fire or shock hazard, do not place objects filled with liquids, such as vases, on the apparatus.

Do not install this equipment in a confined space, such as a bookshelf or similar unit.

- Please ensure that the AC power outlet (mains socket) is installed near the equipment and shall be easily accessible.
- Be sure to use the supplied AC adapter and AC power cord (mains lead). Otherwise it may cause a malfunction.
- Connect the AC adapter to an easily accessible AC power outlet (mains socket).
- Do not coil the AC power cord (mains lead) around the AC adapter. The core wire may be cut and/or it may cause a malfunction of the TV.
- Do not touch the AC adapter with wet hands.
- If you notice an abnormality in the AC adapter, disconnect it from the AC power outlet (mains socket) immediately.
- The set is not disconnected from the AC source as long as it is connected to the AC power outlet (mains socket), even if the set itself has been turned off.
- As the AC adapter will become warm when it is used for a long time, you may feel hot when touching it by hand.



Prohibited Usage

Do not install/use the TV set in locations, environments or situations such as those listed below, or the TV set may malfunction and cause a fire, electrical shock, damage and/or injuries.

Location:

- Outdoors (in direct sunlight), at the seashore, on a ship or other vessel, inside a vehicle, in medical institutions, unstable locations, near water, rain, moisture or smoke.
- If the TV is placed in the changing room of a public bath or hot spring, the TV may be damaged by airborne sulphur, etc.



- For best picture quality, do not expose the screen to direct illumination or sunlight.
- Avoid moving the TV from a cold area to a warm area. Sudden room temperature changes may cause moisture condensation. This may cause the TV to show poor picture and/or poor colour. Should this occur, allow moisture to evaporate completely before powering the TV on.

Environment:

- Places that are hot, humid, or excessively dusty; where insects may enter; where it might be exposed to mechanical vibration, near flammable objects (candles, etc.). The TV set shall not be exposed to dripping or splashing and no objects filled with liquids, such as vases, shall be placed on the TV.

- Do not place the TV in a humid or dusty space, or in a room with oily smoke or steam (near cooking tables or humidifiers). Fire, electric shock, or warping may result.



- Do not install the TV in places subject to extreme temperature, such as in direct sunlight, near a radiator or a heating vent. The TV may overheat in such conditions which can cause deformation of the enclosure and/or TV malfunction.

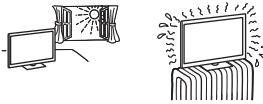

Situation:

- Do not use when your hands are wet, with the cabinet removed, or with attachments not recommended by the manufacturer. Disconnect the TV set from AC power outlet (mains socket) and antenna (aerial) during lightning storms.
- Do not install the TV so that it sticks out into an open space. Injury or damage from a person or object bumping into the TV may result.

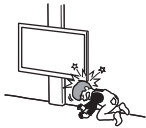

Broken pieces:

- Do not throw anything at the TV set. The screen glass may break by the impact and cause serious injury.
- If the surface of the TV set cracks, do not touch it until you have unplugged the AC power cord (mains lead). Otherwise electric shock may result.

When not in use

- If you will not be using the TV set for several days, the TV set should be disconnected from the AC power (mains) for environmental and safety reasons.
- As the TV set is not disconnected from the AC power (mains) when the TV set is just turned off, pull the plug from the AC power outlet (mains socket) to disconnect the TV set completely.
- However, some TV sets may have features that require the TV set to be left in standby to work correctly.

For children

- Do not allow children to climb on the TV set.
- Keep small accessories out of the reach of children, so that they are not mistakenly swallowed.

If the following problems occur...

Turn off the TV set and unplug the AC power cord (mains lead) immediately if any of the following problems occur. Ask your dealer or Sony service centre to have it checked by qualified service personnel.

When:

- AC power cord (mains lead) is damaged.
- Poor fitting of AC power outlet (mains socket).
- TV set is damaged by being dropped, hit or having something thrown at it.
- Any liquid or solid object falls through openings in the cabinet.

About LCD Monitor Temperature

When the LCD Monitor is used for an extended period, the panel surrounds become warm. You may feel hot when touching there by the hand.

WALL-MOUNT BRACKET

Below information shows the correct handling of the Wall-Mount Bracket. Be sure to read this information thoroughly and use the Wall-Mount Bracket correctly.

To Customers:

Be sure to observe the following precautions for safety to prevent a serious injury through fire, electric shock, the product toppling over, or the product dropping.

- Be sure to subcontract the installation to licensed contractors and keep small children away during installation.
- Be sure to subcontract moving or dismantling of the TV to licensed contractors.
- Do not remove screws, etc., after mounting the TV.
- Do not make alterations to the parts of the Wall-Mount Bracket.
- Do not mount any equipment other than the specified product.
- Do not apply any load other than the TV on the Wall-Mount Bracket.
- Do not lean on or hang from the TV.
- Do not handle the TV with excessive force during cleaning or maintenance.

To Sony Dealers and Contractors:

The following instructions are for Sony dealers and contractors only. Be sure to read safety precautions described below and pay special attention to safety during the installation, maintenance and checking of this product.

- When handling or mounting the TV set, hold it on the sides. Do not lift the TV by the Stand.

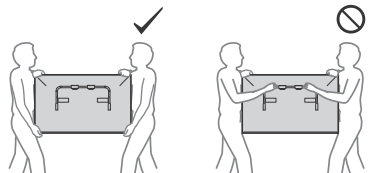
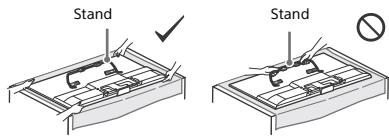

- Do not install the Wall-Mount Bracket on wall surfaces where the corners or the sides of the TV are protruding away from the wall surface.
- Do not install the TV over or under an air conditioner.



- Be sure to install the Wall-Mount Bracket securely to the wall following the instructions in this instruction manual. If any of the screws are loose or fall out, the Wall-Mount Bracket may fall and cause injury or property damage.
- Be sure to use the supplied screws and attachment parts properly following the instructions given in this instruction manual. If you use substitute items, the TV may fall and cause bodily injury to someone or damage to the TV.
- Be sure to assemble the bracket properly following the instructed procedure explained in this instruction manual.
- Be sure to tighten the screws securely in the designated position.
- Be careful not to subject the TV to shock during installation.
- Be sure to install the TV on a wall that is both perpendicular and flat.
- After proper installation of the TV, secure the cables properly.
- Do not allow the AC power cord (mains lead) or the connecting cables to be pinched as the internal conductors may become exposed and cause a short circuit or an electrical break.

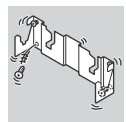

Precautions

Viewing the TV

- Some people may experience discomfort (such as eye strain, fatigue, or nausea) while watching 3D video images or playing stereoscopic 3D games. Sony recommends that all viewers take regular breaks while watching 3D video images or playing stereoscopic 3D games. The length and frequency of necessary breaks will vary from person to person. You must decide what works best. If you experience any discomfort, you should stop watching the 3D video images or playing stereoscopic 3D games until the discomfort ends; consult a doctor if you believe necessary. You should also review (i) the instruction manual of any other device or media used with this television and (ii) our website (<http://www.sony-asia.com/support>) for the latest information. The vision of young children (especially those under six years old) is still under development. Consult your doctor (such as a paediatrician or eye doctor) before allowing young children to watch 3D video images or play stereoscopic 3D games. Adults should supervise young children to ensure they follow the recommendations listed above.
- Do not use, store, or leave the 3D Glasses or battery near a fire, or in places with a high temperature, e.g., in direct sunlight, or in sun-heated cars.
- View the TV in moderate light, as viewing the TV in poor light or during long period of time, strains your eyes.
- When using headphones, adjust the volume so as to avoid excessive levels, as hearing damage may result.

LCD Screen

- Although the LCD screen is made with high-precision technology and 99.99% or more of the pixels are effective, black dots may appear or bright points of light (red, blue, or green) may appear constantly on the LCD screen. This is a structural property of the LCD screen and is not a malfunction.
- Do not push or scratch the front filter, or place objects on top of this TV set. The image may be uneven or the LCD screen may be damaged.
- If this TV set is used in a cold place, a smear may occur in the picture or the picture may become dark. This does not indicate a failure. These phenomena disappear as the temperature rises.
- Ghosting may occur when still pictures are displayed continuously. It may disappear after a few moments.
- The screen and cabinet get warm when this TV set is in use. This is not a malfunction.
- The LCD screen contains a small amount of liquid crystal. Follow your local ordinances and regulations for disposal.

Handling and cleaning the screen surface/ cabinet of the TV set

Be sure to unplug the AC power cord (mains lead) connected to the TV set from AC power outlet (mains socket) before cleaning. To avoid material degradation or screen coating degradation, observe the following precautions.

- To remove dust from the screen surface/cabinet, wipe gently with a soft cloth. If dust is persistent, wipe with a soft cloth slightly moistened with a diluted mild detergent solution.
- Never spray water or detergent directly on the TV set. It may drip to the bottom of the screen or exterior parts and enter the TV set, and may cause damage to the TV set.



- Never use any type of abrasive pad, alkaline/acid cleaner, scouring powder, or volatile solvent, such as alcohol, benzene, thinner or insecticide. Using such materials or maintaining prolonged contact with rubber or vinyl materials may result in damage to the screen surface and cabinet material.
- Periodic vacuuming of the ventilation openings is recommended to ensure proper ventilation.
- When adjusting the angle of the TV set, move it slowly so as to prevent the TV set from moving or slipping off from its table stand.

Optional Equipment

Keep optional components or any equipment emitting electromagnetic radiation away from the TV set. Otherwise picture distortion and/or noisy sound may occur.

Wireless Function of the unit

- Do not operate this unit near medical equipment (pacemaker, etc.), as malfunction of the medical equipment may result.
- Although this unit transmits/receives scrambled signals, be careful of unauthorised interception. We cannot be responsible for any trouble as a result.

Caution about handling the remote control

- Observe the correct polarity when inserting batteries.
- Do not use different types of batteries together or mix old and new batteries.
- Dispose of batteries in an environmentally friendly way. Certain regions may regulate the disposal of batteries. Please consult your local authority.
- Handle the remote control with care. Do not drop or step on it, or spill liquid of any kind onto it.
- Do not place the remote control in a location near a heat source, a place subject to direct sunlight, or a damp room.

WALL-MOUNT BRACKET

- If you use the TV installed on the Wall-Mount Bracket for a long time, the wall behind or above the TV may become discoloured or the wallpaper may come unglued, depending on the material of the wall.
- If the Wall-Mount Bracket is removed after installing it on the wall, the screw holes remain.
- Do not use the Wall-Mount Bracket in a place where it is subjected to mechanical vibration.

GB

Parts and Controls

Controls and Indicators

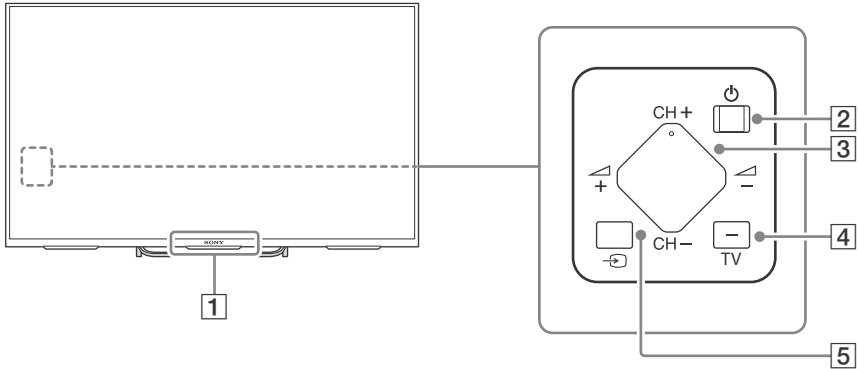

1 Remote Control sensor* / Light sensor* / Illumination LED / 3D Sync Transmitter*

The Illumination LED lights up or blinks according to the status of the TV.

- White
When turning on the TV/picture off mode/software update, etc.
- Cyan
When connecting with a mobile device wirelessly.
- Amber
Timer is set.

2  (Power)

3 CH +/- (Channel)

 +/- (Volume)

4 TV

Switch to a TV channel or input from other applications.

5  (Input select)

Display and select the input source.

* Do not place anything near the sensor.

Inputs and Outputs

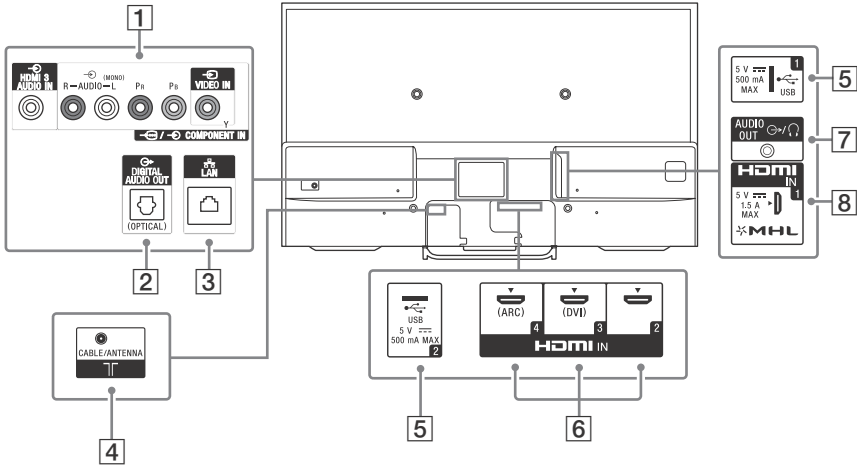

GB

1 VIDEO IN, COMPONENT IN

- For a composite connection:
Use VIDEO IN, and (L/R) of COMPONENT IN*.
- For a component connection:
Use Y, PB, PR, and (L/R).

HDMI 3 AUDIO IN

For HDMI 3 analogue audio connection.

2 DIGITAL AUDIO OUT (OPTICAL)

3 LAN

4 CABLE/ANTENNA

Connect to your cable or antenna (aerial).

5 USB 1/2

- Connecting a large USB device may interfere with other connected devices beside it.
- When connecting a large USB device, connect to the USB 1 socket.

6 HDMI IN 2/3/4

- If the device has a DVI jack (socket), connect it to HDMI IN 3 through a DVI - HDMI adaptor interface (not supplied), and connect the device's audio out jacks (sockets) to HDMI 3 AUDIO IN.
- If connecting a digital audio system that is compatible with Audio Return Channel (ARC) technology, use HDMI IN 4. If not, an additional connection with DIGITAL AUDIO OUT (OPTICAL) is necessary.

7 AUDIO OUT

To listen to the TV's sound through the connected equipment, press **HOME**. Select [Settings] → [Sound] → [Headphone/Audio Out] and then select the desired item.

8 HDMI IN 1/MHL

You can connect your MHL (Mobile High-definition Link) device using an HD quality MHL cable.

* When connecting mono equipment, connect to the L (MONO) audio jack.

Using Remote Control

Remote Control Parts Description

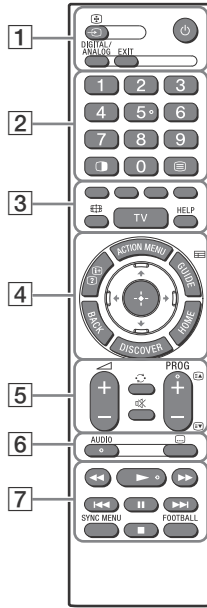

1 (Input select/Text hold)

In TV mode: Display and select the input source.

In Text mode: Hold the current page.

(TV standby)

Turn on or turn off the TV (standby mode).

DIGITAL/ANALOG

Switch between digital and analogue mode.

EXIT

Return to the previous screen or exit from the menu. When an Interactive Application service is available, press to exit from the service.

2 Number buttons

(Twin picture/PIP)*1+2

Display two pictures simultaneously.

(Text)

Display text information.

3 Colour buttons

Execute correspondent function at that time.

(Wide mode)

Change the screen format.

TV

Switch to a TV channel or input from other applications.

HELP

Display Help Menu.

4 ACTION MENU

Display a list of contextual functions.

 (Info/Text reveal)

Display information.

GUIDE/*1

Display the digital programme guide.

BACK

Return to previous screen.

HOME

Display the TV Home Menu.

DISCOVER

Bring up the Content Bar to search for content.

 (Item select/Enter)**5  +/- (Volume)**



Adjust the volume.

 (Jump)



Jump back and forth between two channels or inputs. The TV alternates between the current channel or input and the last channel or input that was selected.

 (Muting)

Mute the sound. Press again to restore the sound.

PROG +/-/

In TV mode: Select the channel.

In Text mode: Select the next () or previous () page.

6 AUDIO

Change the language for the programme currently being viewed.

 (Subtitle setting)

Turn subtitles on or off (when the feature is available).

7 

Operate media contents on TV and connected BRAVIA Sync-compatible device.

SYNC MENU

Display the BRAVIA Sync Menu.

FOOTBALL

Turn Live Football Mode on or off (when the feature is available).

*1 The location, availability and function of remote control button may vary depending on your country/region/TV model.

*2 Twin Picture function will be available from July 2015. You will receive Twin Picture function automatically as a network software upgrade. Make sure your TV is connected to the Internet. If you do not have a network connection, you will be able to download the software from the Sony support website using your PC. For details on how to upgrade, please visit the Sony support website.

Connecting the TV

Note

- When connecting the cable to the Cable/Antenna, input finger tighten only, over-tightening the connection can damage the TV.

To connect with an HDMI cable

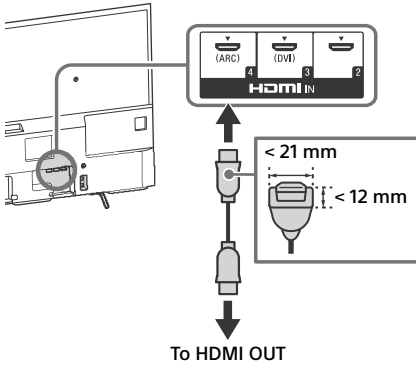

To connect with AV composite cables

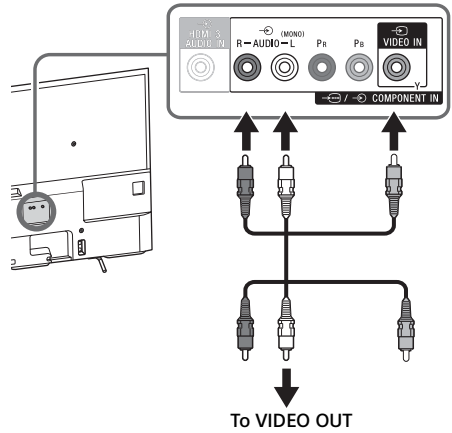

To connect with component cables

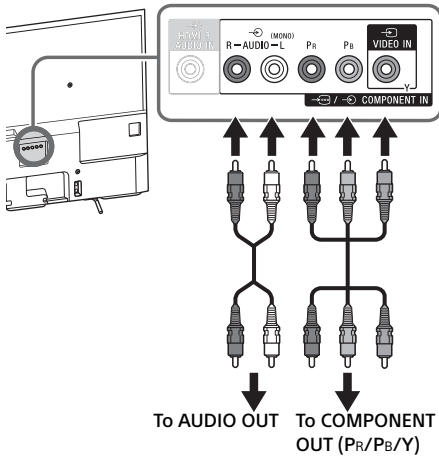

Picture Quality

- AV composite cable
- Antenna (aerial) cable
- Component cable
- HDMI cable

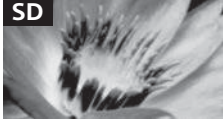

Standard definition (SD) videos have picture signals with a vertical resolution of 480 (NTSC) or 576 (PAL/SECAM) lines.



High definition (HD) videos have picture signals with a vertical resolution of 720 or 1,080 lines.

GB

Installing the TV to the Wall

Using your TV's Table-Top Stand as a Wall-Mount Bracket

To Customers

Sufficient expertise is required for installing this product. Be sure to subcontract the installation to Sony dealers or licensed contractors and pay special attention to safety during the installation. Sony is not liable for any damages or injury caused by mishandling or improper installation, or installing any other than the specified product. Your Statutory Rights (if any) are not affected.

To Sony Dealers and Contractors

Sufficient expertise is required for installing this product. Be sure to read this instruction manual thoroughly to do the installation work safely. Sony is not liable for any damages or injury caused by mishandling or improper installation.

Your TV's Table-Top Stand will be used as a part of the Wall-Mount Bracket.

Note

- See page 2 (Safety Information) and page 5 (Precautions) on WALL-MOUNT BRACKET before carrying out Wall-Mount Bracket installation.
- If the Table-Top Stand is attached to the TV, detach the Table-Top Stand beforehand.
- Place the TV with its screen facing down on a flat and stable surface covered with a thick and soft cloth that is larger than the TV, when securing the Stand or when removing the Table-Top Stand from the TV to prevent damaging the surface of the LCD display.
- Once the Stand Necks are detached from the Stand, be sure to keep the Stand Necks and screws in a safe place.
- When attaching the Table-Top Stand again, be sure to fasten the screws (previously removed) to the original holes on the rear of the TV.

To detach the Table-Top Stand from the TV

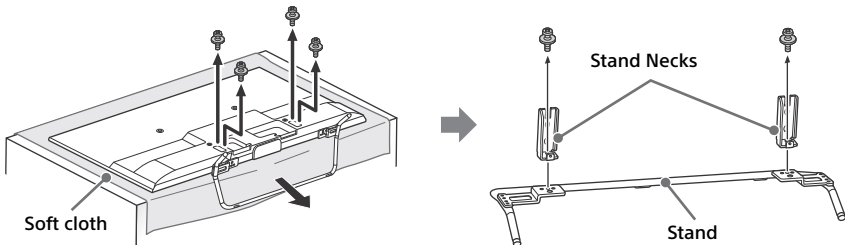

Installing the Brackets on the wall

1 Prepare necessary items.

Wall-Mount Bracket accessories **H**

- A** Paper Template
- B** Wall-Mount Base (1)
- C** Stand Protector (2)
- D** Screw (+PSW M8 × 12) (2)

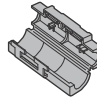
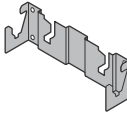
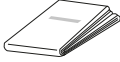

- E** Spacers (2)



Stand **B**



Screws for Wall-Mount Base (8 mm in diameter, not supplied)

- ## 2 Make sure that the wall has enough space for the TV and is capable of supporting a weight of at least four times that of the TV.
- Refer to the following table on installing the TV to the wall. See page 22-24 (Specifications) for the TV's weight.

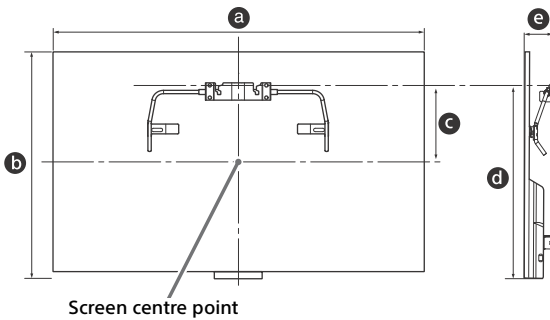

Model Name KDL-	Display dimensions		Screen centre dimension	Length for mounting	
	a	b	c	d	e
50W800C	1,116	654	215	552	87
43W800C	962	565	253	544	87

Note

- Figures in the table may differ slightly depending on the installation.

3 Make a mark on the Paper Template (A) that indicates the centre of the screen for your TV.

Scale on Paper Template (A)

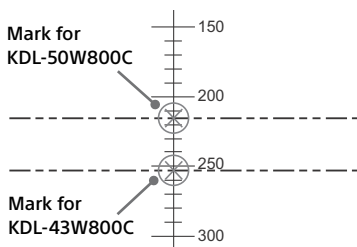

4 Tape the Paper Template (A) to the wall and drill holes according to the numbering on the Paper Template (A) using an electric drill.

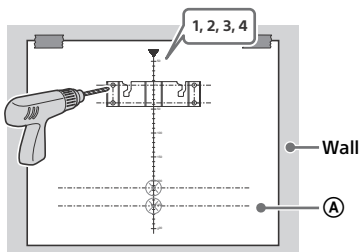

5 Remove the Paper Template (A) off from the wall.

6 Attach the Wall-Mount Base (B) to the wall correctly using the screws (8 mm in diameter, not supplied).

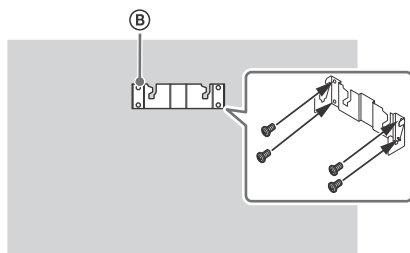

Preparing for the installation of the TV

- 1 Insert the pin (on the Stand Protector ③) into the hole on the Stand ②, then fold up the Stand Protector ③. Confirm the Stand Protector ③ is firmly latched to the Stand ②.

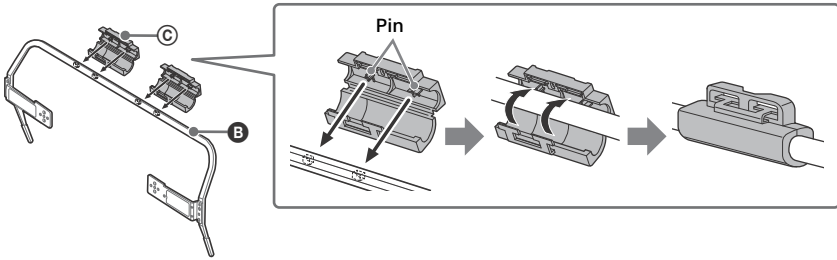

GB

- 2 Attach the Stand ② to the TV using the supplied screws ④. Attach the Spacers ⑤ to the holes indicated by the triangle marks △.

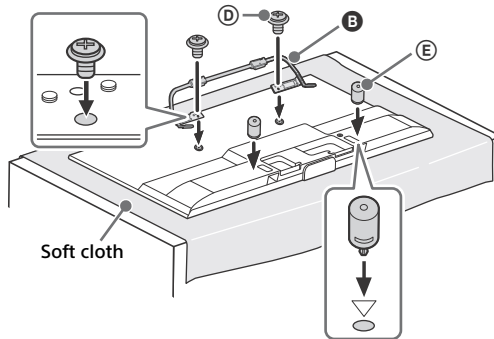

Note

- You cannot use some of the terminals on the rear of the TV when using this mounting style.

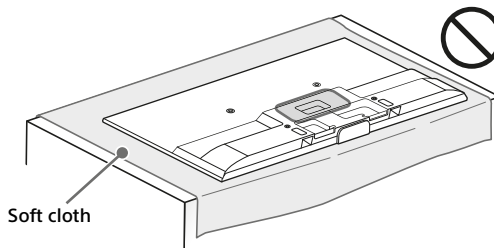

Installing the TV on the wall

- 1 Make sure to connect and bundle the cables before installing the TV on the wall.
- 2 Install the TV on the wall. Then, confirm the Stand Protector © is firmly latched into the Wall-Mount Base ② and the Spacers ⑤ touch the wall.

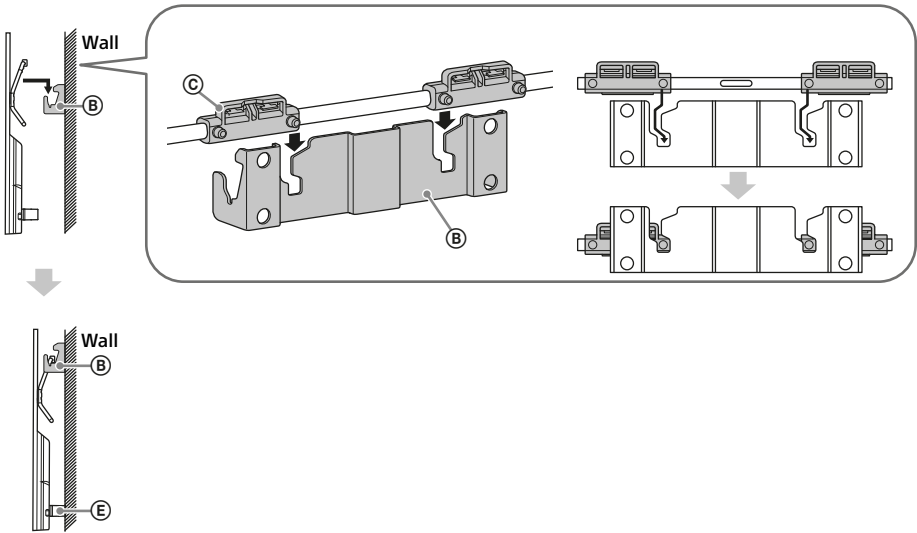

Dimensions of the hole positions on the wall

Provide the following information to the licensed contractors if necessary.

Use screws (8 mm in diameter, not supplied) to install the Wall-Mount Base ② on the wall.

Be sure to use the supplied Paper Template ④ that shows the actual position of Wall-Mount Base ② for easy installation.

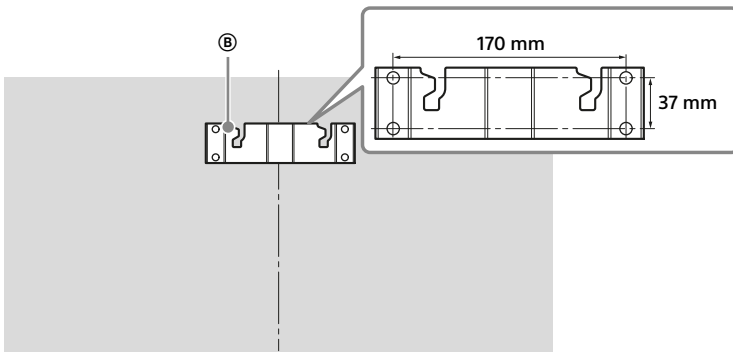

Using an optional Wall-Mount Bracket

This TV's instruction manual only shows the steps on preparing the installation of the TV before installing to the wall.

To Customers:

For product protection and safety reasons, Sony strongly recommends that installation of your TV be performed by Sony dealers or licensed contractors. Do not attempt to install it yourself.

To Sony Dealers and Contractors:

Provide full attention to safety during the installation, periodic maintenance and examination of this product.

GB

Sufficient expertise is required for installing this product, especially to determine the strength of the wall for withstanding the TV's weight. Be sure to entrust the attachment of this product to the wall to Sony dealers or licensed contractors and pay adequate attention to safety during the installation. Sony is not liable for any damage or injury caused by mishandling or improper installation.

Use the Wall-Mount Bracket SU-WL450 (not supplied) to install the TV to the wall. When installing the Wall-Mount Bracket, also refer to the Operating Instructions and Installation Guide supplied with the Wall-Mount Bracket.

Note

- Be sure to store the removed screws in a safe place, keeping them away from children.
- See page 2 (Safety Information) and page 5 (Precautions) on WALL-MOUNT BRACKET before carrying out Wall-Mount Bracket installation.
- If the Table-Top Stand is attached to the TV, detach the Table-Top Stand beforehand.
- Place the TV with its screen facing down on a flat and stable surface covered with a thick and soft cloth that is larger than the TV, when securing the Stand or when removing the Table-Top Stand from the TV to prevent damaging the surface of the LCD display.
- When attaching the Table-Top Stand again, please refer Startup Guide to fasten the screws (previously removed) to the original holes on the rear of the TV.

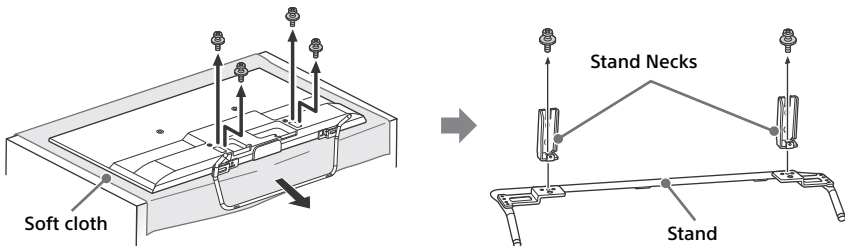

SU-WL450

- 1 Attach Wall-Mount Attachment ❶ (supplied with the TV) to the rear of the TV (to make it parallel with the wall).

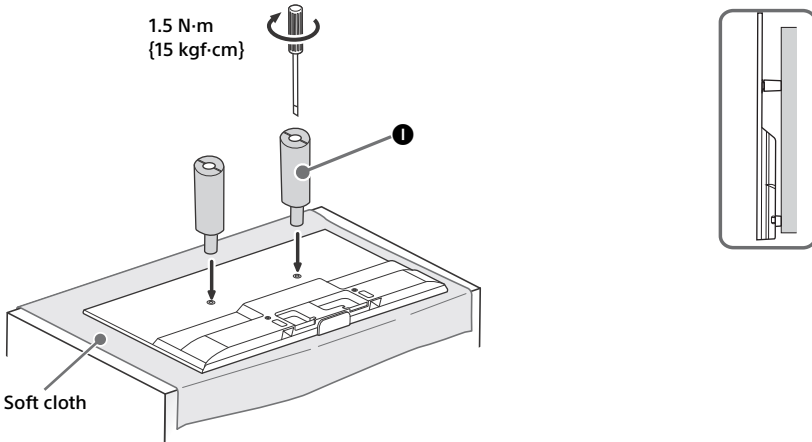

Note

- If using an electric screwdriver, set the torque at approximately 1.5 N·m {15 kgf·cm}.
- Be sure to fasten the Wall-Mount Attachment when attaching them to the TV.
Use only a flat head screwdriver to install the Wall-Mount Attachment. Use of another tool might result in over-torquing the Wall-Mount Attachment and damaging the TV.

- 2 Make sure that the wall has enough space for the TV and is capable of supporting a weight of at least four times that of the TV. Refer to the following table on installing the TV to the wall. See page 22-24 (Specifications) for the TV's weight.

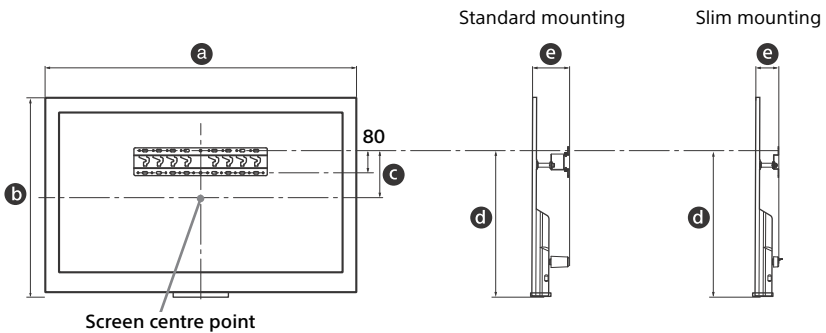

Model Name KDL-	Display dimensions		Screen centre dimension	Length for mounting		
	a	b	c	d	e	
					Standard mounting	Slim mounting
50W800C	1,116	654	127	464	122	80
43W800C	962	565	173	464	122	80

Note

- Figures in the table may differ slightly depending on the installation.
- When your TV is installed on the wall, the upper side of the TV slightly leans forward.

3 Attach the Attachment parts for Wall-Mount Bracket. Check the Attachment parts by referring to "1" of the Wall-Mount Bracket Installation Guide.

Note

- If using an electric screwdriver, set the torque at approximately 1.5 N·m (15 kgf·cm).
- Be sure to store the unused parts in a safe place for future use. Retain this manual for future reference.

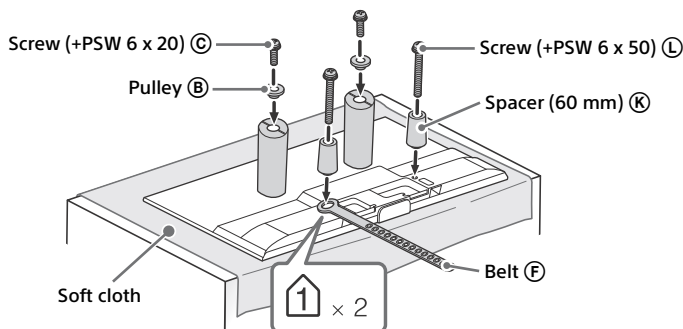
Standard mounting**Slim mounting****Note**

- You cannot use some of the terminals on the rear of the TV when using this mounting style.

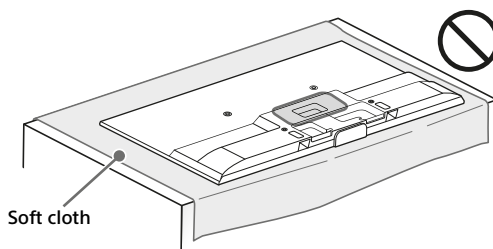

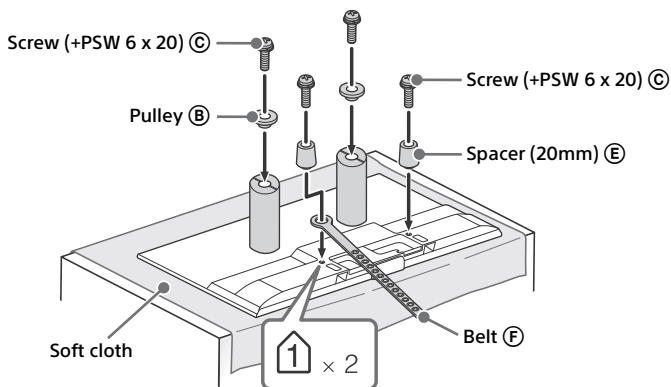

4 Connect necessary cables to the TV.

Note

- You cannot access to any terminal after installing the TV to the wall.

5 Install the TV to the Base. Refer to "5" of Installation Guide and "Installing the TV to the Wall" of Operating Instructions supplied with the Wall-Mount Bracket.

Model Name KDL-	Hook location
50W800C/ 43W800C	a

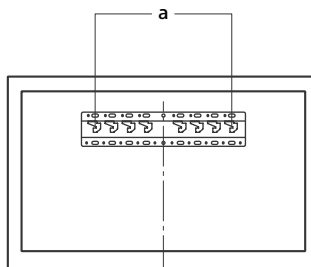

Refer to the instructions supplied with the Wall-Mount Bracket for your model to install the TV on the wall.

Troubleshooting

In order to keep your TV software up-to-date, it is necessary to download the latest software information via the digital broadcasting system or Internet and to update the software. Select [Update Now] to start a software update. The illumination LED flashes white while the software is updating. Do not unplug the AC power cord during the software update. If you do, the software update may not finish completely, and it may cause a software malfunction. Software updates can take up to 30 minutes. If you do not wish to update the software automatically, press **HOME** and select [Help] → [System software update] → [Automatic software download] → [Off].

When you unplug the TV and plug it in again, the TV may not be able to turn on for a while even if you press the power button on the remote control or the TV because it takes time to initialize the system. Wait for about 10 to 20 seconds, then operate it again.

When the illumination LED is flashing red, count how many times it flashes (interval time is three seconds).

If the illumination LED flashes red, reset the TV by disconnecting the AC power cord (mains lead) from the TV for two minutes, then turn on the TV.

If the problem persists, contact your dealer or Sony service centre with the number of times the illumination LED flashes red (interval time is three seconds). Disconnect the AC power cord (mains lead), and inform your dealer or Sony service centre.

When the illumination LED is not flashing, check the items as follows.

You can also refer to [Troubleshooting] in the Help Guide or perform self-diagnosis by selecting [Help] → [Self Diagnostics]. If the problem persists, have your TV serviced by qualified service personnel.

Troubles and Solutions

There is no picture (screen is dark) and no sound.

- Check the antenna (aerial)/cable connection.
- Connect the TV to the AC power (mains), and press \odot on the TV or remote control.

Some programmes cannot be tuned.

- Check the antenna (aerial)/cable connection.

The remote control does not function.

- Replace the batteries.

The [Parental lock] password has been forgotten.

- Enter 9999 for the PIN code. (PIN code 9999 is always accepted.)

The TV surrounds become warm.

- When the TV is used for an extended period, the TV surrounds become warm.
You may feel hot when touching there by the hand.

Frozen audio or video, a blank screen, or the TV does not respond to TV or remote control buttons.

- Perform a simple reset of the TV by unplugging the AC power cord (mains lead) for two minutes, then plug it in again.

The \odot , CH+/-, \triangle +/-, \square and TV buttons cannot be located on the TV.

- See below illustration for location of the buttons on the TV.

Rear of TV

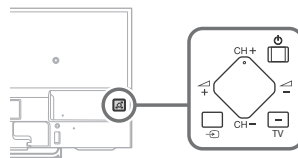

The illumination LED is turned on.

- If you do not wish to light up the illumination LED, you can turn it off.
Press **HOME**, then select [Settings] → [Illumination LED] → [Off].

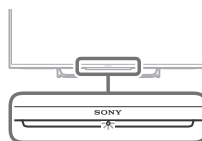

Cannot connect to a wireless router by WPS (Wi-Fi Protected Setup).

- If you use WEP security, select [Easy] → [Wi-Fi] → [Connect by scan list]. Then, select the network name (SSID) you want to connect.

Cannot find the required network name in network setup.

- Select [[Manual Entry]] and press ⊕ to enter network name.

Specifications

System

Panel system

LCD (Liquid Crystal Display) Panel, LED Backlight

TV system

Analogue: B/G, I, D/K, M

Digital: DTMB

Colour/video system

Analogue: PAL, SECAM, NTSC3.58, NTSC4.43

Digital: Refer to the Help Guide

Channel coverage

Analogue: UHF/VHF/Cable

Digital: UHF

Sound output

10 W + 10 W

Wireless technology

Protocol IEEE802.11a/b/g/n

Bluetooth Version 4.1

Input/Output jacks

Antenna (aerial)/cable

75 ohm external terminal for VHF/UHF

 /  COMPONENT IN

YPbPr (Component Video): 1080p (50, 60 Hz),

1080i (50, 60 Hz), 720p (50, 60 Hz), 576p, 576i,

480p, 480i

Audio input (phono pin jack)

 VIDEO IN

Video input (common phono pin with Y input)

HDMI IN 1, 2, 3, 4

Video (2D): 1080p (30, 50, 60 Hz), 1080/24p, 1080i (50, 60 Hz), 720p (30, 50, 60 Hz), 720/24p, 576p, 576i, 480p, 480i, PC Formats

Video (3D):

Frame Packing: 1080p (30 Hz), 1080/24p,

1080i (50, 60 Hz), 720p (30, 50, 60 Hz), 720/24p

Side-by-Side: 1080p (50, 60 Hz), 1080/24p,

1080i (50, 60 Hz), 720p (50, 60 Hz)

Over-Under: 1080p (30, 50, 60 Hz), 1080/24p,

1080i (50, 60 Hz), 720p (50, 60 Hz)

Audio: 5.1 channel linear PCM: 32, 44.1, 48, 88.2, 96, 176.4 and 192 kHz, 16, 20 and 24 bits, Dolby Digital and DTS

ARC (Audio Return Channel) (HDMI IN 4 only)

MHL (common with HDMI IN 1)

Video (2D): 1080p (30 Hz), 1080/24p, 1080i (50, 60 Hz), 720p (30, 50, 60 Hz), 720/24p, 576p, 576i, 480p, 480i

Video (3D):

Side-by-Side: 1080/24p, 1080i (50, 60 Hz), 720p (50, 60 Hz)

Over-Under: 1080p (30 Hz), 1080/24p, 1080i (50, 60 Hz), 720p (50, 60 Hz)

Audio: 5.1 channel linear PCM: 32, 44.1, 48, 88.2, 96, 176.4 and 192 kHz, 16, 20 and 24 bits, Dolby Digital and DTS

Ⓞ DIGITAL AUDIO OUT (OPTICAL)

Digital optical jack (Two channel linear PCM, Dolby Digital and DTS)

Ⓜ HDMI 3 AUDIO IN

Analogue audio input (Stereo mini jack)

AUDIO OUT / (Stereo mini jack)

Headphone, Audio Output, Subwoofer

Ⓜ1, Ⓜ2

USB port

ⓂⓂ DC IN 19.5 V

AC adapter input

LAN

10BASE-T/100BASE-TX connector (Depending on the operating environment of the network, connection speed may differ. 10BASE-T/100BASE-TX communication rate and communication quality are not guaranteed for this TV.)

Others

Optional accessories

Touchpad Remote Control: RMF-TX100E

Wall-Mount Bracket: SU-WL450

Wireless Subwoofer: SWF-BR100

MHL Cable: DLC-MC10/DLC-MC20

Active 3D Glasses: TDG-BT500A



Operating temperature

0 °C – 40 °C

Operating humidity

10 % – 80 % RH (non-condensing)

Power and others

Power requirements

19.5 V DC with AC adapter

Rating: Input 220 V - 240 V AC, 50 Hz

Screen size (measured diagonally) (Approx.)

KDL-50W800C: 50 inches / 125.7 cm

KDL-43W800C: 43 inches / 108.0 cm

Display resolution

1,920 dots (horizontal) × 1,080 lines (vertical)

Power consumption

KDL-50W800C: 94 W

KDL-43W800C: 82 W

Dimensions (Approx.) (w × h × d)

with Table-Top Stand

KDL-50W800C: 1,116 × 691 × 191 mm

KDL-43W800C: 962 × 602 × 179 mm

without Table-Top Stand

KDL-50W800C: 1,116 × 654 × 59 mm

KDL-43W800C: 962 × 565 × 59 mm

Mass (Approx.)

with Table-Top Stand

KDL-50W800C: 14.6 kg

KDL-43W800C: 11.8 kg

without Table-Top Stand

KDL-50W800C: 13.7 kg

KDL-43W800C: 10.9 kg

Note

- Optional accessories availability depends on country/region/TV model/stock.
- Design and specifications are subject to change without notice.
- This TV set incorporates MHL 2.

Trademark information

- The terms HDMI and HDMI High-Definition Multimedia Interface, and the HDMI Logo are trademarks or registered trademarks of HDMI Licensing LLC in the United States and other countries.
- Manufactured under license from Dolby Laboratories. Dolby and the double-D symbol are trademarks of Dolby Laboratories.
- "BRAVIA" and BRAVIA are trademarks of Sony Corporation.
- Gracenote, Gracenote eyeQ, Gracenote VideoID, Gracenote Video Explore, the Gracenote logo and logotype, and the "Powered by Gracenote" logo are either registered trademarks or trademarks of Gracenote in the United States and/or other countries.
- Opera® Devices SDK from Opera Software ASA. Copyright 1995-2014 Opera Software ASA. All rights reserved.
- Wi-Fi, Wi-Fi Direct, Miracast and Wi-Fi Protected Setup are trademarks or registered trademarks of Wi-Fi Alliance.

- MHL, Mobile High-Definition Link and the MHL Logo are trademarks or registered trademarks of MHL Licensing, LLC.
- For DTS patents, see <http://patents.dts.com>. Manufactured under license from DTS, Inc. DTS, the Symbol, & DTS and the Symbol together are registered trademarks, and DTS Digital Surround is a trademark of DTS, Inc. © DTS, Inc. All Rights Reserved.
- Designed with UEI Technology™ Under License from Universal Electronics Inc. Portions © UEI 2000 – 2014
- The Bluetooth® word mark and logos are owned by the Bluetooth SIG, Inc. and any use of such marks by Sony Corporation is under license. Other trademarks and trade names are those of their respective owners.
- ©2015 RealNetworks, Inc. Patents Pending. All rights reserved. RealNetworks logo is a trademark of RealNetworks, Inc.
- TUXERA is a registered trademark of Tuxera Inc. in the US and other countries.



目錄

安全資訊	2
預先注意事項	4
組件及控件	6
控件及指示燈	6
輸入及輸出	7
使用遙控器	8
遙控器組件說明	8
連接電視機	10
將電視機安裝在牆上	12
將電視機的桌面底座用作壁掛式支架	12
使用選購的壁掛式支架	17
故障排除	21
故障及解決方案	21
規格	22

簡介

感謝您購買這項 Sony 產品。
使用電視機之前，請詳閱本手冊，並保留下來以便將來參考。

註

- 使用電視機之前，請詳讀“安全資訊”(第2頁)。
- 有關“將電視機安裝在牆上”的指令已包含在這台電視機的說明手冊。
- 入門指南和本說明書中使用的影像和插圖僅作參考並可能與實際產品的外觀不同。

識別標籤的位置

電視機型號和電源等級的標籤位於電視機背面。
AC 電源供應器型號和序號的標籤位於 AC 電源供應器的底部。

本電視設計在香港使用，只保證能在香港使用。

安全資訊

警告

不可將電池曝露於如陽光、火或類似的過熱源。

安裝 / 設定

為了避免火災、觸電或損壞及 / 或受傷等危險，請遵照下列指示來安裝和使用電視機。

安裝

- 應將電視機安裝在易於插拔的 AC 電源插座附近。
 - 將電視機擺在平穩的水平表面上，以防止傾倒而造成人員的傷害或者損及電視機。
 - 僅可由合格的維修人員執行掛壁安裝。
 - 為了安全起見，強烈建議您使用 Sony 配件，包括：
 - 壁掛式支架 (附帶)
 - 壁掛式支架 SU-WL450
 - 將掛鉤 (底座) / 壁掛式支架安裝於電視機上時，務必要使用隨附於壁掛式支架的螺絲。隨附螺絲如插圖所示設計從掛鉤 (底座) / 壁掛式支架安裝表面量起。
- 螺絲的直徑和長度會因為壁掛式支架的型號而有所不同。
使用隨附螺絲以外的螺絲可能會造成電視機內部損壞或者掉落等等。

— 壁掛式支架 (附帶)

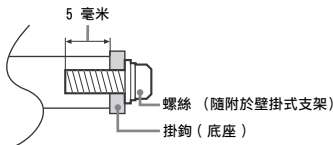

— 壁掛式支架 SU-WL450

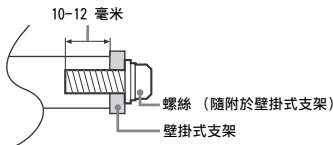

搬動

- 搬動電視機之前，請斷開所有訊號線的連接。
- 大尺寸電視機需要兩到三人搬動。
- 用手搬動電視機時，請如下圖所示抓握。請勿對液晶面板以及螢幕周圍的框邊施加壓力。

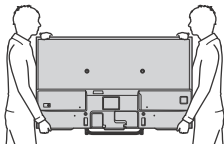

- 搬動電視機時，請勿使其受到搖晃或過度震動。
- 搬動電視機以進行維修或移動時，請使用原有的紙箱和包裝材料進行包裝。

通風

- 切勿遮擋通風孔或將任何物體插入機殼內。
- 如下圖所示，在電視機周圍保留通風空間。
- 強烈建議您使用 Sony 壁掛式支架以確保足夠的空氣流通。

安裝在牆壁上

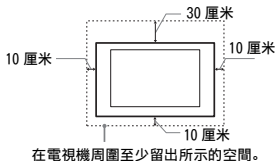

在電視機周圍至少留出所示的空間。

安裝在底座上

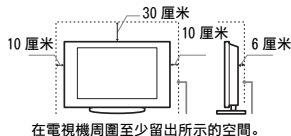

在電視機周圍至少留出所示的空間。

- 為了確保正確通風及防止髒物或灰塵堆積：
 - 請勿將電視機平放、上面朝下安裝、向後安裝或側面安裝。
 - 請勿將電視機放置於架子、地毯、床或壁櫥中。
 - 請勿用布（如窗簾）或物件（如報紙等）覆蓋電視機。
 - 請勿如下圖所示安裝電視機。

空氣流通被阻擋。

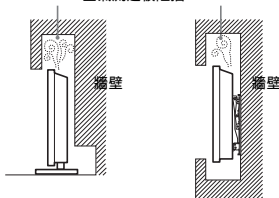

AC 電源線

為了避免火災、觸電或損壞及 / 或受傷等危險，請遵照下列指示來處理 AC 電源線和插座：

- 請僅使用 Sony 隨附的 AC 電源線，不要使用其它品牌的電源線。
- 將插頭完全插入 AC 電源插座。
- 僅可在 220-240 V AC 電源上使用電視機。
- 連接訊號線時，為了安全起見請務必拔下 AC 電源線，以免被訊號線絆到腳。
- 在進行作業或移動電視機之前，請從 AC 電源插座上斷開 AC 電源線的連接。
- 保持 AC 電源線遠離熱源。
- 拔下 AC 電源插頭，定期進行清潔。如果插頭上有積灰並帶有濕氣，則其絕緣品質可能已經劣化，並可能會造成火災。

註

- 請勿在任何其它設備上使用所隨附的 AC 電源線。
- 請勿過度掙捏、彎曲或扭轉 AC 電源線。否則線芯可能會曝露在外或折斷。
- 請勿改裝 AC 電源線。

- 請勿將任何重物放在 AC 電源線上。
- 斷開 AC 電源線連接時，請勿拉扯 AC 電源線。
- 請勿在相同的 AC 電源插座上連接太多設備。
- 請勿使用不適當的 AC 電源插座。

AC 電源供應器的注意事項

警告

為了減低火災或觸電的風險，請勿讓本裝置暴露於雨水或濕氣中。為了避免火災或觸電的危險，請勿將盛裝液體的物體，例如花瓶放在裝置上。

請勿將本設備安裝在狹窄封閉的空間，例如書架或類似裝置。

- 請確保將 AC 電源線安裝在設備附近並易於插拔。
- 請務必使用隨附的 AC 電源供應器和 AC 電源線。否則這可能導致故障。
- 將 AC 電源供應器連接至易於插拔的 AC 電源插座。
- 請勿將 AC 電源線盤繞在 AC 電源供應器上。芯線可能折斷並（或）導致電視機故障。
- 手濕時請勿觸碰 AC 電源供應器。
- 如果您發現 AC 電源供應器異常，立刻將 AC 電源供應器從 AC 電源插座拔下。
- 只要本機仍然連接至 AC 電源插座，即使本機已經關閉，AC 電源還是未切斷。
- 由於 AC 電源供應器在長時間使用後會發熱，用手觸摸時可能會感到發熱。

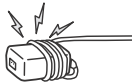

CT

使用限制

請勿在下列地點、環境或情況條件下安裝 / 使用電視機，否則電視機可能會發生故障並造成火災、觸電、損壞及 / 或受傷等危險。

地點：

- 室外（在直射的陽光中）、海邊、船上或其他船舶上，車內，醫療機構中，不穩定的場所，靠近水、雨、濕氣或煙霧的地方。
- 如果放置電視機在公共浴室或溫泉的更衣室內，電視機可能會被空降硫磺等損壞。



- 若要獲得最佳的畫面品質，請勿將螢幕放在直射光源或陽光下。
- 避免將電視機從寒冷的區域移至溫熱的區域。突然的室溫變化可能導致濕氣凝結。這可能造成電視機顯示劣質圖像及 / 或暗淡的顏色。如果發生這種情形，讓濕氣完全蒸發之後再開啟電視機。

環境：

- 炎熱、潮濕或太多灰塵的地方，昆蟲可能進入的地方；可能受到機械式震動的地方；靠近易燃物體（蠟燭等）的地方。不應該讓液體滴灑或噴濺電視機，而且裝滿液體的物體（例如花瓶）不應該擺在電視機上。
- 不要放置電視機在潮濕或多塵的空間，或有油煙或蒸氣的場所（靠近灶台或加濕器）。這可能導致火災、觸電或本機彎曲。



- 請勿將電視機安裝在會遭受極端溫度的位置，如陽光直射、靠近散熱器或加熱裝置通風孔的地方。電視機在這種環境下可能會過熱而導致外殼變形及 / 或電視機故障。

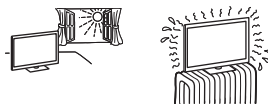

情況條件：

- 手濕，機殼拆除或採用非製造商所建議的配件時切勿使用本電視機。出現雷電時請將電視機電源線從 AC 電源插座和天線拔下。
- 不要把電視機安裝在延伸出開放的空間。這可能導致人或物體碰撞電視機而受傷或損壞。



打破電視機螢幕：

- 請勿將任何物品丟向電視機。否則螢幕可能會因為受到撞擊而破裂並造成嚴重傷害。
- 如果電視機的表層破裂，在拔下 AC 電源線以前請勿觸摸它。否則可能會導致觸電。

不使用時

- 如果您不使用電視數天，為了環保和 safety 原因，應將電視機電源線從 AC 電源插座上拔下。
- 關閉電視機電源時，電視機並未與 AC 電源斷開連接，請將插頭從 AC 電源插座上拔下以完全斷開電視機的電源連接。
- 但是，某些電視機可能具有需要將電視機保持在待命模式下才能正常工作的特點。

對於兒童

- 請勿讓兒童爬上電視機。
- 將體積小的配件放在兒童拿不到的地方，以便不會被兒童誤吞。

如果出現下列問題...

如果出現以下任何問題，請立刻關閉電視機並拔下 AC 電源線。請諮詢您的經銷商或 Sony 服務中心以交由合格的服務人員進行檢查。

當：

- AC 電源線損壞。
- AC 電源插座不適當。
- 電視機由於跌落、敲擊或撞擊而損壞。
- 任何液體或固體物件通過開口處掉入機殼內。

關於液晶螢幕溫度

長時間使用液晶螢幕時，面板周圍溫度會升高。用手觸摸這些地方時可能會覺得很燙。

壁掛式支架

以下資訊說明壁掛式支架的正確使用方式。請務必詳盡地閱讀這些資訊並正確使用壁掛式支架。

致客戶：

- 請務必遵守以下的安全預先注意事項，以預防因火災、觸電、產品翻倒或產品掉落造成嚴重傷害。
- 請務必將安裝的工作委託授權承包商進行並在安裝進行時確保兒童遠離安裝地點。
- 請務必將搬運或拆卸電視機的工作委託授權承包商進行。
- 安裝電視機之後，請勿拆下螺絲等。
- 請勿改造壁掛式支架的部件。
- 請勿安裝指定產品以外的任何設備。
- 請勿在壁掛式支架上施加電視機以外的任何負重。
- 請勿倚靠或坐在電視機上或懸空緊握電視機。
- 請勿在清潔或維修電視機時過度施力於電視機。

致 Sony 經銷商和承包商：

- 以下指示僅適用於 Sony 經銷商和承包商。請務必閱讀以下所述的安全預先注意事項。在安裝、維修和檢查本產品時，請格外小心。
- 處理或安裝電視機時，請抓握其側面。請勿攪住底座以擡起電視機。



- 請勿將壁掛式支架安裝在使電視機角落或邊緣突出的牆面。
- 請勿將電視機安裝在空調機之上或之下。

- 請務必按照本使用說明書中的指示將壁掛式支架牢固地安裝至牆壁。如果任何螺絲鬆開或脫落，壁掛式支架可能掉落並導致受傷或財物損失。
- 請務必按照本使用說明書中的指示正確地使用隨附的螺絲和附件。如果您使用替代物品，電視機可能掉落並導致人身傷害或電視機損壞。
- 請務必按照本使用說明書解釋的指導程序正確地裝配支架。
- 請務必在指定的位置鎖緊螺絲。
- 小心不要讓電視機在安裝過程中承受震動。
- 請務必將電視機安裝在垂直和平坦的牆上。
- 在正確安裝電視機之後，妥當地固定螺絲。
- 不要讓 AC 電源線或連接線材受到擠壓，內部導體可能因此裸露並導致短路或遭電擊穿。

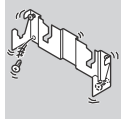

預先注意事項

觀賞電視

- 在觀看 3D 視訊影像或打立體的 3D 電玩期間，有些人可能會感到不適（如眼睛疲勞、疲累或噁心）。Sony 建議所有觀賞者在觀看 3D 視訊影像或打立體的 3D 電玩期間要定期休息。休息的長度和頻率因人而異。由您自行決定。若您感到任何不適，請停止觀看 3D 視訊影像或打立體的 3D 電玩，直到不適感消失；若有必要，請就醫。關於最新資訊，也請您參閱 (i) 用於電視機的其他設備或媒體的使用說明書，以及 (ii) 我們的網站 (<http://www.sony-asia.com/support>)。兒童（尤其是低於六歲的兒童）的視力還在發育。讓兒童觀看 3D 視訊影像或打立體的 3D 電玩前，請諮詢醫師（如小兒科醫師或眼科醫師）。成人應監督兒童，確保他們遵守上述建議事項。
- 不要在靠近火源或高溫地方如直射陽光或太陽曬熱的汽車內使用、貯存或留下 3D 眼鏡或電池。
- 請在適當光線條件下觀賞電視，因為在光線不足條件下或長時間觀賞電視會損傷您的眼睛。
- 使用耳機時，請調整音量以免音質過高損傷聽力。

LCD 螢幕

- 雖然 LCD 螢幕採用最精密技術製造且 99.99% 以上的畫素有效，但還是可能會出現黑點或 LCD 螢幕上可能會經常出現亮點（紅、藍或綠色）。這是 LCD 螢幕的結構特性，並不是故障。
- 請勿按壓或刮傷前濾光面板或在電視機頂部放置物件。畫面可能會不均，或者 LCD 螢幕可能會損壞。
- 如果在寒冷地點使用本電視機，畫面上可能會出現模糊或變暗。這並不是故障。溫度上升後這些現象就會消失。
- 畫面靜止不動時會產生重影。片刻後該現象將消失。
- 電視機使用過程中，螢幕和機殼會發熱。這不是故障。
- LCD 螢幕包含少量液晶。請按照您當地的法規進行廢棄物處理。

使用和清潔電視機的螢幕表層 / 機殼

清潔前，務必將電視機的 AC 電源線從 AC 電源插座上斷開連接。為了避免物質或螢幕塗層剝離，請遵照下列預先注意事項。

- 若要擦去螢幕表層 / 機殼上的灰塵，請用軟布輕輕擦拭。如果灰塵較難除去，請用稍稍蘸有稀釋中性清潔劑的軟布進行擦拭。
- 絕對不能將水或清潔劑直接噴灑在電視上。液體可能滴落在螢幕的底部或外部零件上並滲入電視內，而毀壞電視。



- 切勿使用任何類型的磨砂墊、鹼性 / 酸性清潔劑、擦洗粉或揮發溶劑，如酒精、汽油、稀釋劑或殺蟲劑。使用上述材料或與橡膠或乙烯材料長時間接觸可能會造成螢幕表層和機殼材料的損壞。
- 建議您定期使用真空吸塵器清理通風口以確保通風順暢。
- 當調整電視機的角度時，請慢慢地調動以防電視機從其桌面型底座移動或滑落。

選購設備

將產生電磁輻射的選購元件或任何其他設備遠離電視機。否則可能會造成畫面失真及 / 或噪聲。

本機的無線功能

- 請勿在醫療設備（心臟起搏器等等）附近操作本機，這將導致該醫療設備故障。
- 雖然本機發送 / 接收加擾信號，請小心未經授權的截取。我們不對此造成的任何問題負責。

注意有關處理遠程控制

- 安裝電池時請注意正確的極性位置。
- 請勿同時使用不同類型的電池或混合使用新舊電池。
- 請以符合環境保護規定的方式來丟棄電池。特定地區可能有制訂廢棄電池的相關規定。請向您當地的主管機關查詢。
- 請小心拿取遙控器。請勿讓遙控器掉落或踩在遙控器上，或是讓任何液體灑到遙控器。
- 請勿將遙控器放置在接近熱源的地方，放置在受日光直射地方或潮濕的房間。

壁掛式支架

- 如果您長時間使用壁掛式支架安裝電視機，視牆壁的材料而定，位於電視機後方或上方的牆面可能變色或壁紙失去黏性。
- 如果拆下原來安裝在牆上的壁掛式支架，牆面上將留下螺絲孔痕跡。
- 請勿在容易受到振動的地方使用壁掛式支架。

組件及控件

控件及指示燈

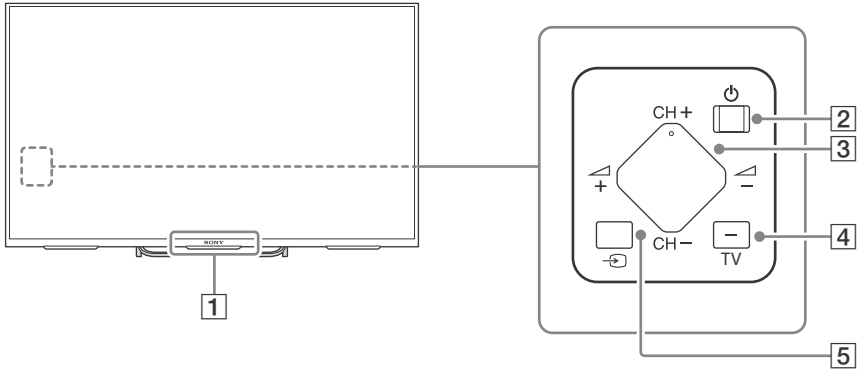

- 1 遙控器感應器* / 光感應器* / 照明 LED / 3D 同步發射機*

照明 LED 會根據電視機的狀態而亮起或閃爍。

- 白色
開啟電視機 / 關閉畫面模式 / 軟體更新等時。
- 青色
無線連接行動裝置時。
- 琥珀色
計時器已設定。

- 2 (電源)

- 3 CH +/- (頻道)
+/- (音量)

- 4 TV
切換至一個電視頻道或從其他應用程式輸入。

- 5 (輸入選擇)
顯示並選擇輸入來源。

*請勿在感應器附近放置任何物品。

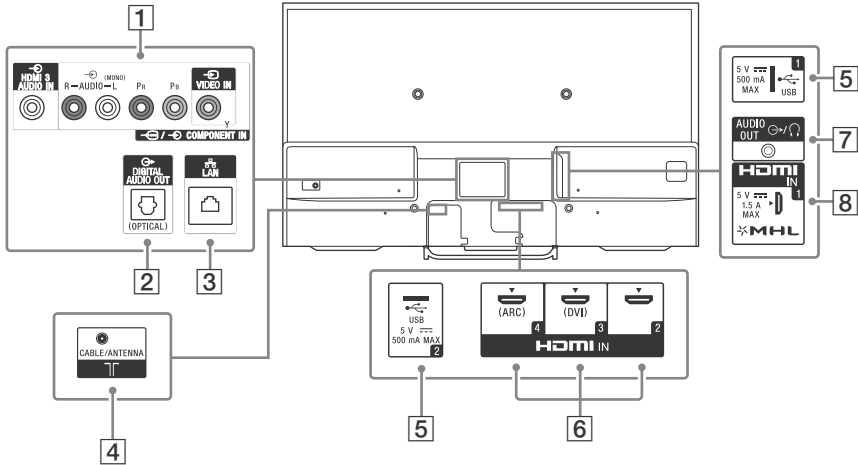

1 VIDEO IN, COMPONENT IN

- 如為複合連接：
使用 VIDEO IN，以及 COMPONENT IN 的 (L/R)*。
- 如為組件連接：
使用 Y、Pb、Pr 及 (L/R)。

⇒ HDMI 3 AUDIO IN

如為 HDMI 3 類比音訊連接。

2 DIGITAL AUDIO OUT (OPTICAL)

3 LAN

4 CABLE/ANTENNA

連接至連接線或天線。

5 USB 1/2

- 連接大型 USB 裝置可能會干擾旁邊連接的其他裝置。
- 連接大型 USB 裝置時，請連接至 USB 1 插座。

6 HDMI IN 2/3/4

- 如果裝置擁有 DVI 插座，請透過 DVI - HDMI 轉接器接口（無附帶）將其連接至 HDMI IN 3，並將裝置的音訊輸出插孔（插座）連接至 HDMI 3 AUDIO IN。
- 如果連接與音訊回傳信道（ARC）技術相容的數位音訊系統，請使用 HDMI IN 4。否則，必須額外連接 DIGITAL AUDIO OUT (OPTICAL)。

7 AUDIO OUT

如需透過相連設備聆聽電視聲音，請按 **HOME**。選擇 [設定] → [聲音設定] → [耳機/聲音輸出]，並選擇所需的項目。

8 HDMI IN 1/MHL

您可以使用高畫質 MHL 連接線連接 MHL（行動高畫質連接技術）裝置。

*連接單聲道設備時，請連接至 L (MONO) 音訊插孔。

使用遙控器

遙控器組件說明

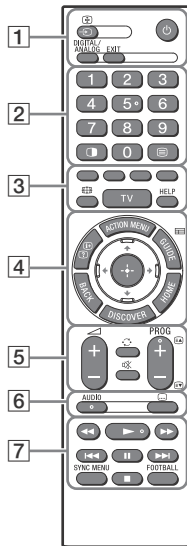

1 (輸入選擇 / 文字保留)

電視模式：顯示並選擇輸入來源。
文字模式：保留當前頁面。

(電視待機)

開啟或關閉電視機 (待機模式)。

DIGITAL/ANALOG

在數位及類比模式之間切換。

EXIT

返回至上一個畫面，或從選單退出。如果交互式應用服務可供使用，按下即可退出服務。

2 數字按鈕

(雙重畫面 / PIP)*1*2
同時顯示兩個畫面。

(文字)
顯示文字資訊。

3 顏色按鈕

屆時執行相應的功能。



(寬螢幕模式)
變更螢幕格式。

TV
切換至一個電視頻道或從其他應用程式輸入。

HELP
顯示說明選單。

4 ACTION MENU

顯示情境功能清單。

 /  (顯現資訊 / 文字)

顯示資訊。

GUIDE / *1

顯示數位節目指南。

BACK

返回上一個畫面。

HOME

顯示電視主選單。

DISCOVER

調出內容列，搜尋內容。

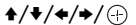
 (項目選擇 / 輸入)

5 +/- (音量)



調節音量。

 (跳轉)



在兩個頻道或兩次輸入之間前後跳轉。電視在當前頻道 / 輸入以及選擇的上一個頻道 / 輸入之間交替切換。

 (靜音)

將聲音消除。再次按下可恢復聲音。

PROG +/- /  / 

電視模式：選擇頻道。

文字模式：選擇下一個 () 或上一個 () 頁面。

6 AUDIO

變更目前觀看之節目的語言。

 (字幕設定)

開啟或關閉字幕 (此功能可用時)。

7

在電視機及相連的 BRAVIA Sync 相容裝置上操作媒體內容。

SYNC MENU

顯示 BRAVIA 同步選單。

FOOTBALL

開啟或關閉實況足球模式 (此功能可用時)。

*1 遙控器按鈕的位置、可用性與功能視您的國家 / 區域 / 電視機型號而可能略有不同。

*2 雙重畫面功能自 2015 年 7 月起提供。您將透過軟件網絡升級自動接收雙重畫面功能。確保電視機已連接至互聯網。如果連接網絡，您可以使用 PC 從 Sony 支援網站下載軟件。關於如何升級的詳細資料，請瀏覽 Sony 支援網站。

連接電視機

註

- 將連接線連接至連接線 / 天線，僅用手緊固，連接過緊可能會損壞電視機。

以 HDMI 連接線連接

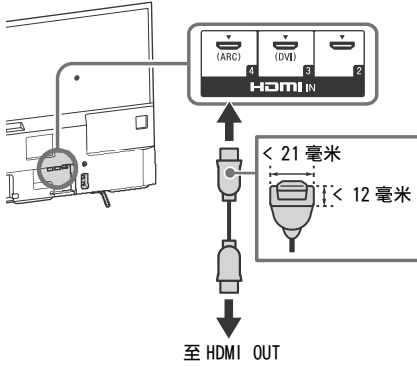

以色差纜線連接

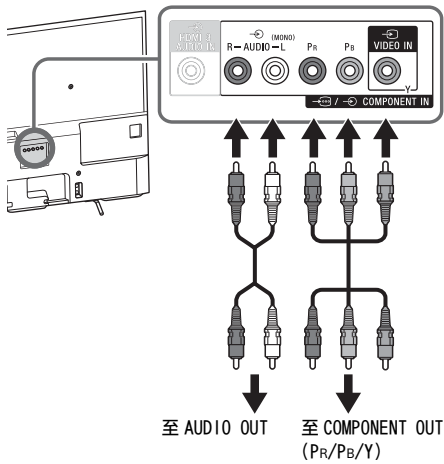

以 AV 複合訊號線連接

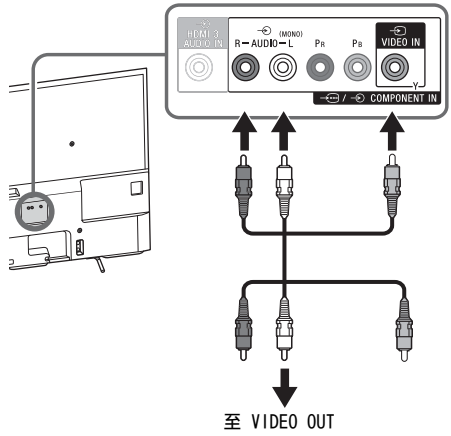

圖像品質

- AV 複合訊號線
- 天線的連接訊號線

- 色差訊號線

- HDMI 訊號線

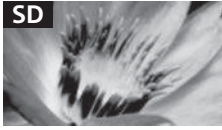

標準清晰度 (SD) 視訊圖像信號的垂直解析度為 480 (NTSC) 或 576 (PAL/SECAM) 條線。



高清晰度 (HD) 視訊圖像信號的垂直解析度為 720 或 1080 條線。

將電視機安裝在牆上

將電視機的桌面底座用作壁掛式支架

致客戶

安裝本產品需要足夠的專業技能。務必將安裝的工作委託 Sony 經銷商或授權承包商進行，並在安裝時特別注意安全。Sony 對於任何因為錯誤操作或不當安裝，或安裝指定產品以外的任何其他產品所造成的損壞或傷害恕不負責。您的法定權利（如有）不會受到影響。

致 Sony 經銷商和承包商

安裝本產品，尤其是在確定牆壁強度是否能夠支撐電視機重量方面，需要足夠的專業知識。將本產品安裝於牆上的工作務必要委託 Sony 經銷商或經過授權的承包商進行，而且安裝時要特別注意安全。Sony 對於任何因為錯誤操作或不當安裝所造成的損壞或傷害恕不負責。

您的電視機的桌面底座將被用為壁掛式支架的一部分。

註

- 在進行壁掛式支架的安裝之前，請參閱第 2 頁（安全資訊）和第 4 頁（預先注意事項）關於壁掛式支架的資訊。
- 如果桌面底座安裝於電視機，預先拆下桌面底座。
- 當安裝掛鉤或從電視機拆下桌面底座時，將電視機以螢幕朝下放置在覆蓋著厚而軟布的平坦和穩固的表面上以避免損壞液晶顯示的表面。
- 一旦將底座頸部從底座拆下之後，務必將底座頸部和螺絲收存在安全的地方。
- 再次安裝桌面底座時，務必將（之前取下的）螺絲鎖緊至電視機背面的原始孔。

將桌面底座從電視機上拆下來

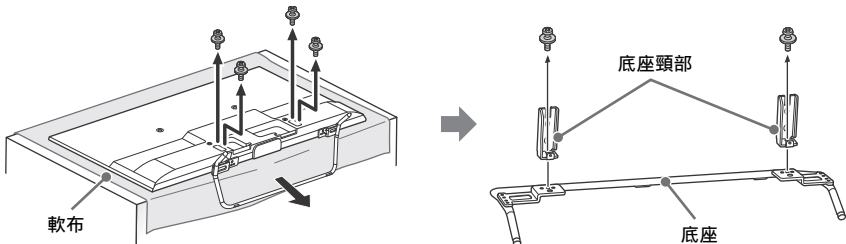

將支架安裝在牆上

1 準備必要的項目。

壁掛式支架配件 **H**

A 紙模板

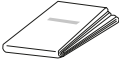

B 壁掛式底座 (1)

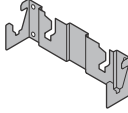

C 底座防護器 (2)



D 螺絲 (+PSW M8 × 12) (2)



E 墊片 (2)



底座 **B**



用於壁掛式底座的螺絲 (直徑 8 毫米, 非附件)

2 確保牆壁有足夠空間以及能支撐至少電視機四倍的重量。 請參閱以下列表有關在牆上安裝電視機。請參閱第 22-24 頁 (規格) 有關電視機的重量。

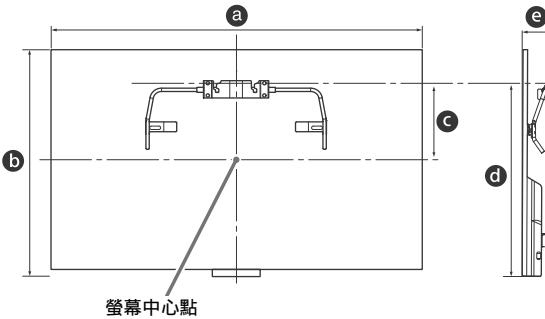

型號名稱 KDL-	顯示幕		螢幕中心尺寸	安裝的長度	
	a	b	c	d	e
50W800C	1,116	654	215	552	87
43W800C	962	565	253	544	87

註

- 製表內的數字視安裝而可能略有不同。

3 在紙模板 ① 上作標記以表示電視機螢幕的中心。

紙模板 ① 上的比例

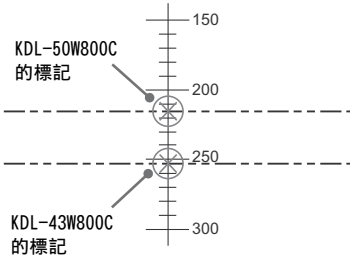

4 用膠紙將紙模板 ① 黏在牆上，然後使用電鑽在紙模板 ① 上根據編號鑽孔。

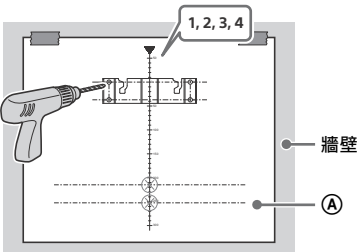

5 從牆上取下紙模板 ①。

6 使用螺絲正確地將壁掛式底座 ② 安裝在牆上（直徑 8 毫米，非附件）。

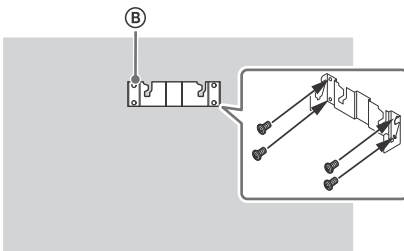

準備安裝電視機

- 1 將針（位於底座防護器 ③ 上）插入底座 ② 上的孔內，然後折起底座防護器 ③。確定底座防護器 ③ 穩固地鎖至底座 ②。

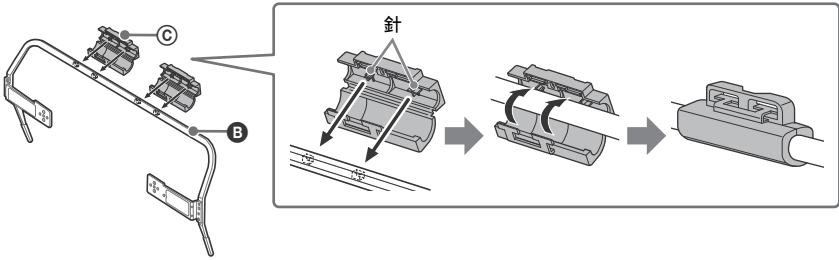

- 2 使用附件的螺絲 ④ 安裝底座 ① 至電視機。將墊片 ⑤ 安裝至由三角形記號 △ 標記的孔內。

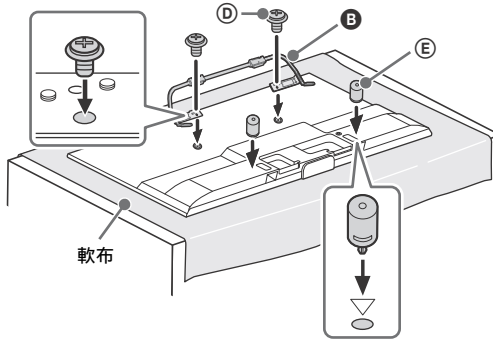

註

- 若選用此安裝樣式，則無法使用電視機後面的某些端子。

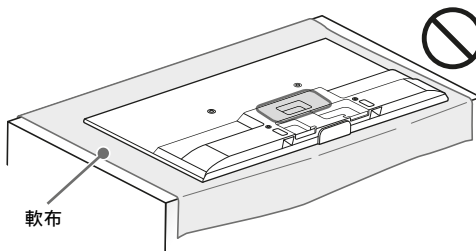

將電視機安裝在牆上

- 1 將電視機安裝在牆上之前，確保先連接和捆紮纜線。
- 2 將電視機安裝在牆上。然後，確定底座防護器 © 穩固地鎖入壁掛式底座 ② 以及墊片 ⑤ 觸及牆壁。

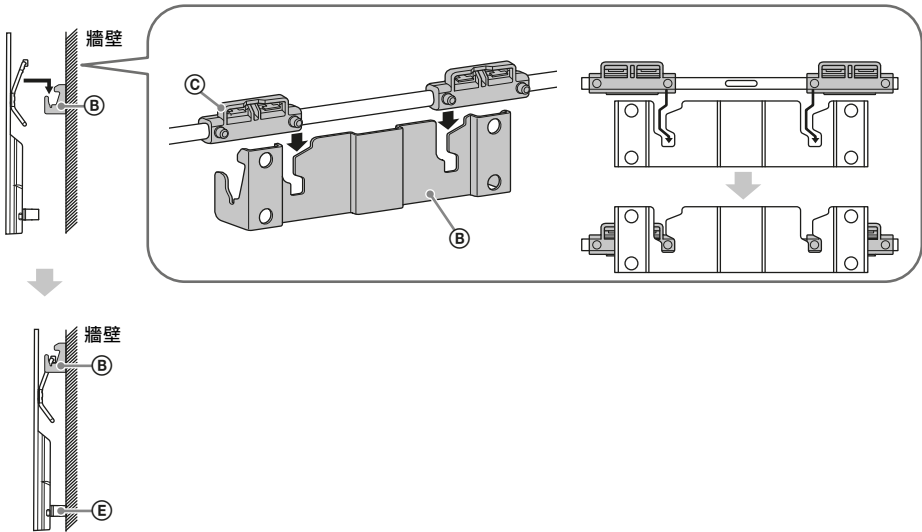

在牆上的孔位置的尺寸

如有需要，將以下資訊提供給授權承包商。

使用螺絲（直徑 8 毫米，非附件）將壁掛式底座 ② 安裝在牆上。

務必使用有顯示壁掛式底座 ② 實際位置的附件紙模板 ① 以便於安裝。

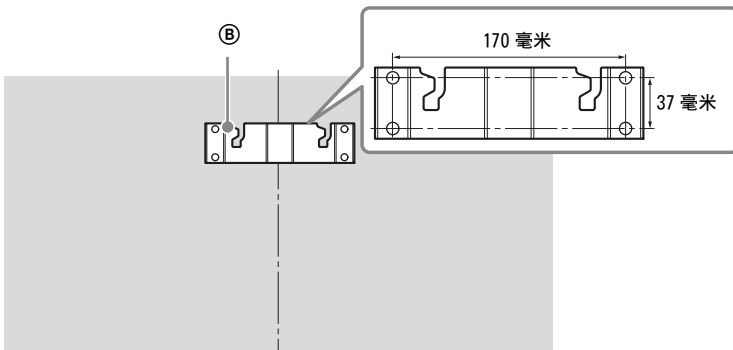

使用選購的壁掛式支架

本電視機的使用說明書僅顯示安裝至牆壁之前的電視機安裝準備工作。

致客戶：

出於產品保護及安全原因，Sony 強烈建議由 Sony 經銷商或授權的承包商安裝電視機。請勿嘗試自行安裝電視機。

致 Sony 經銷商和承包商：

安裝、定期維護及檢查本產品時，請充分注意安全。

安裝本產品須具備充足的專業知識，確定牆壁是否能夠承受電視重量時尤為如此。務必委託 Sony 經銷商或授權的承包商將本產品安裝至牆壁上，並在安裝期間充分注意安全。對於因錯誤操作或安裝不當引致的任何損害，Sony 概不負責。

CT

使用壁掛式支架 SU-WL450（無附帶）將電視機安裝至牆壁上。

安裝壁掛式支架時，亦請參閱壁掛式支架附帶的使用說明書及安裝指南。

註

- 務必將取下的螺絲存放在兒童接觸不到的安全位置。
- 在進行壁掛式支架的安裝之前，請參閱第 2 頁（安全資訊）和第 4 頁（預先注意事項）關於壁掛式支架的資訊。
- 如果桌面底座安裝於電視機，預先拆下桌面底座。
- 當安裝掛鉤或從電視機拆下桌面底座時，將電視機以螢幕朝下放置在覆蓋著厚而軟布的平坦和穩固的表面上以避免損壞液晶顯示的表面。
- 再次安裝桌面底座時，請參閱入門指南，將螺絲（之前已取下）緊固至電視機後面的原始孔內。

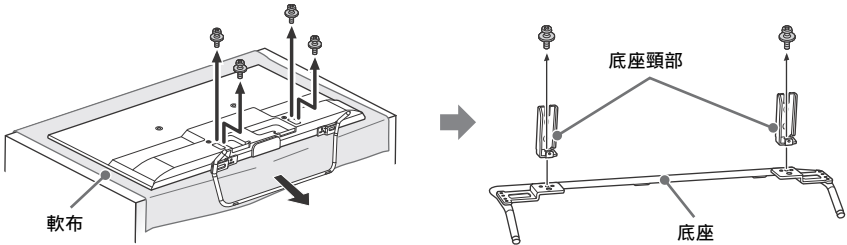

SU-WL450

1 將掛牆式附件 ①（電視機附帶）安裝至電視機後面（使之與牆面平行）。

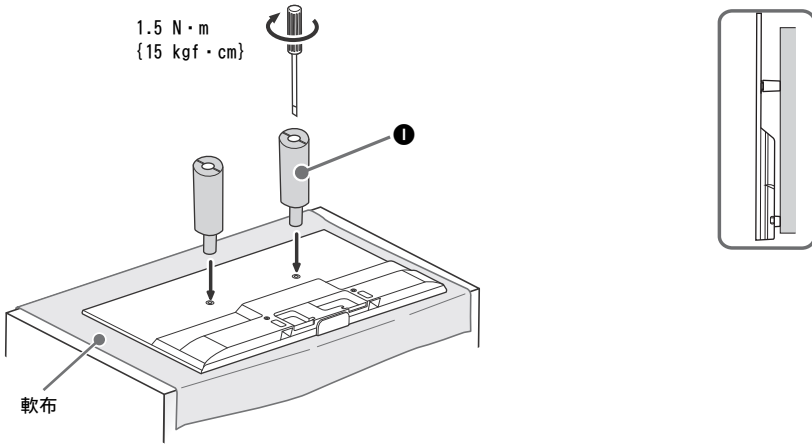

註

- 使用電動螺絲刀時，請將扭力設定為約 1.5 N·m { 15 kgf·cm }。
- 將此類設備連接至電視機時，務必將掛牆式附件固定到位。
只可用平頭螺絲刀安裝掛牆式附件。用其他工具可能導致掛牆式附件過分扭矩，甚至損壞電視機。

2 確保牆壁有足夠空間以及能支撐至少電視機四倍的重量。請參閱以下列表有關在牆上安裝電視機。請參閱第 22-24 頁（規格）有關電視機的重量。

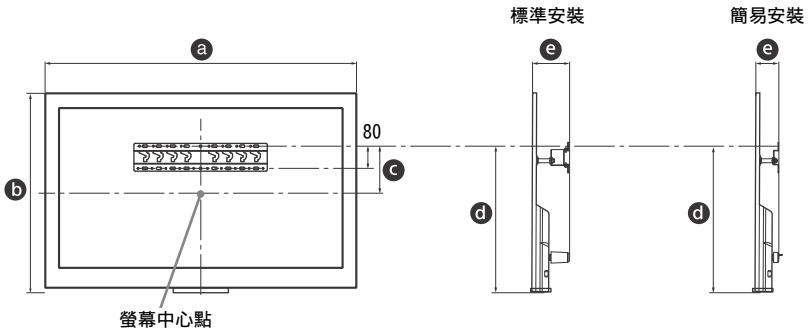

型號名稱 KDL-	顯示幕		螢幕中心 尺寸		安裝的長度	
	a	b	c	d	e	
					標準安裝	簡易安裝
50W800C	1,116	654	127	464	122	80
43W800C	962	565	173	464	122	80

註

- 製表內的數字視安裝而可能略有不同。
- 將電視機安裝至牆壁上後，電視機的上側略微前傾。

3 安裝壁掛式支架的附件組件。參閱壁掛式支架安裝指南之「1」，檢查附件組件。

註

- 使用電動螺絲刀時，請將扭力設定為約 1.5 N·m {15 kgf·cm}。
- 務必將未使用的組件存放於安全位置，以備日後使用。保管好本說明書，以供日後參考。

標準安裝

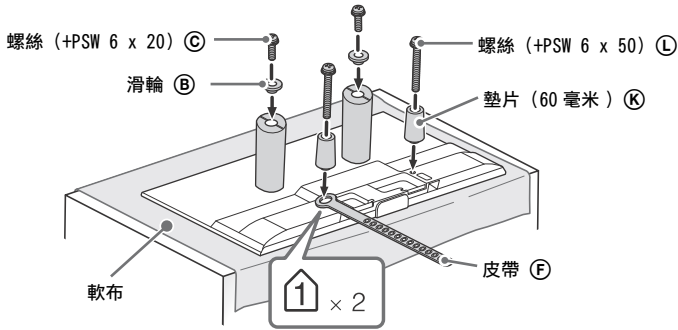

簡易安裝

註

- 若選用此安裝樣式，則無法使用電視機後面的某些端子。

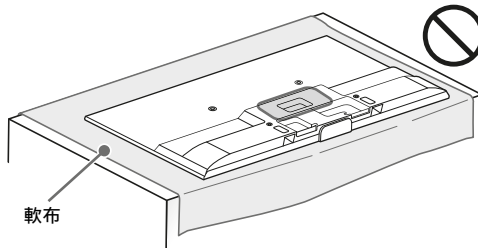

CT

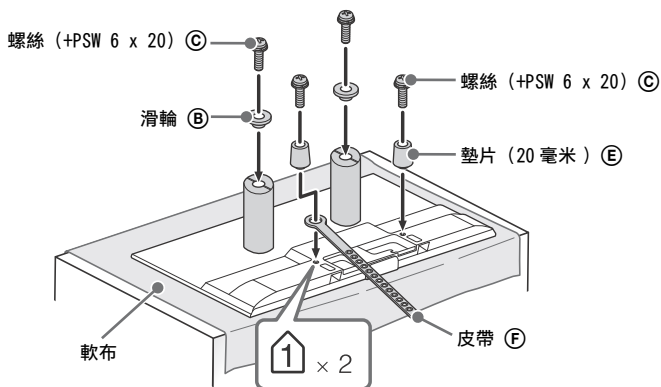

4 將必要的連接線連接至電視機。

註

- 將電視機安裝至牆壁後，無法存取任何端子。

5 將電視機安裝至底座。請參閱壁掛式支架附帶的安裝指南之「5」以及使用說明書之「將電視機安裝至牆壁」。

型號名稱 KDL-	掛鉤位置
50W800C/ 43W800C	a

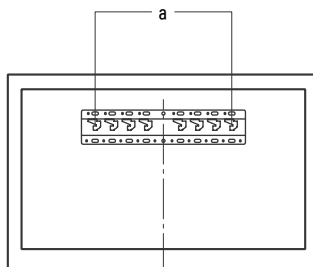

請參閱您所擁有機型之壁掛式支架附帶的說明書，將電視機安裝至牆壁。

故障排除

為了即時更新您的電視軟體，須透過數位廣播系統或網路下載最新軟體資訊，從而更新軟體。選擇 [立即更新] 啟動產品更新。軟體更新時，照明 LED 閃白燈。軟體更新期間，請勿拔出交流電源線。否則，軟體更新不會徹底完成，並且可能引致軟體故障。軟體更新可能持續長達 30 分鐘。如果您不想自動更新軟體，請按 HOME 並選擇 [說明] → [系統軟體更新] → [軟體自動下載] → [關]。

拔出電視機插頭並再次插入時，即使按遙控器或電視機上的電源按鈕，電視機也可能無法開啟，因為啟動系統需要時間。等待約 10 至 20 秒，然後重新操作。

當照明 LED 閃紅燈時，計算閃爍次數（間隔時間為三秒）。

如果照明 LED 閃紅燈，從電視機拔下 AC 電源線，待兩分鐘之後再打開電視機，以進行電視機重設。如果問題仍然存在，請聯繫您的經銷商或 Sony 服務中心並告知照明 LED 閃紅燈的次數（間隔時間為三秒）。拔掉 AC 電源線，然後告訴您的經銷商或 Sony 服務中心。

當照明 LED 沒有閃爍，檢查以下列表中的項目。您也可參閱說明指南中的 [故障排除] 或通過選擇 [說明] → [自行診斷] 以進行自行診斷。如果問題仍然存在，請將您的電視機交給合格的維修人員修理。

故障及解決方案

沒有畫面（螢幕是黑的）也沒有聲音。

- 檢查天線 / 訊號線連接。
- 將電視機連接至 AC 電源，然後按電視機或遙控器上的 。

無法調諧某些節目。

- 檢查天線 / 訊號線連接。

遙控器無效。

- 更換電池。

忘記 [親子鎖碼] 密碼。



- PIN 碼輸入 9999。（PIN 碼 9999 總是可以接受。）

電視機周圍溫度升高。

- 當長時間使用電視機時，電視機周圍溫度會升高。用手觸摸這些地方時可能會覺得很燙。

停頓音訊或視訊、空白螢幕或電視機對電視或遙控器按鈕沒有反應。

- 拔下 AC 電源線兩分鐘之後再次連接以進行簡單的電視機重設。

在電視機上找不到 , CH+/-,  +/-,  和 TV 按鈕。

- 請參閱下圖有關電視機上按鈕的位置。

電視機背面

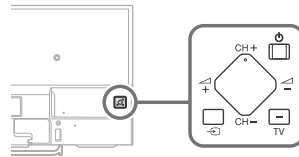

照明 LED 開啟。

- 如果您不要發光 LED 亮起，您可將之關閉。按 HOME，然後選擇 [設定] → [照明 LED] → [關]。

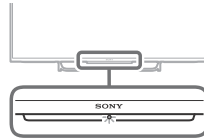

無法以 WPS 連接無線路由器 (Wi-Fi Protected Setup)。

- 如果您使用 WEP 安全加密，選擇 [簡易] → [Wi-Fi] → [依掃描清單連接]。然後，選擇您要連接的網絡名稱 (SSID)。

無法在網絡設定中找到所需的網絡名稱。

- 選擇 [[手動輸入]] 和按  以輸入網絡名稱。

規格

系統

面板系統

LCD (液晶顯示) 面板, LED 背光源

電視系統

類比: B/G, I, D/K, M

數位: DTMB

彩色 / 視訊系統

類比: PAL, SECAM, NTSC3.58, NTSC4.43

數位: 參閱說明指南

頻道涵蓋範圍

類比: UHF/VHF / 訊號線

數位: UHF

聲音輸出

10 瓦 + 10 瓦

無線技術

IEEE802.11a/b/g/n 協議

藍牙版本 4.1

輸入 / 輸出插孔

天線 / 訊號線

VHF/UHF 的 75 歐姆外接端子

COMPONENT IN

YPbPr (色差視頻): 1080p (50, 60 Hz), 1080i (50, 60 Hz), 720p (50, 60 Hz), 576p, 576i, 480p, 480i

音訊輸入 (phono 引腳插孔)

VIDEO IN

視訊輸入 (備有 Y 輸入的常見 phono 針)

HDMI IN 1, 2, 3, 4

視訊 (2D): 1080p (30, 50, 60 Hz), 1080/24p, 1080i (50, 60 Hz), 720p (30, 50, 60 Hz), 720/24p, 576p, 576i, 480p, 480i, PC 格式

視訊 (3D):

幀封裝: 1080p (30 Hz), 1080/24p, 1080i (50, 60 Hz), 720p (30, 50, 60 Hz), 720/24p

並排: 1080p (50, 60 Hz), 1080/24p, 1080i (50, 60 Hz), 720p (50, 60 Hz)

上下格式: 1080p (30, 50, 60 Hz), 1080/24p, 1080i (50, 60 Hz), 720p (50, 60 Hz)

音訊: 5.1 聲道線性 PCM: 32, 44.1, 48, 88.2, 96, 176.4 和 192 kHz, 16, 20 和 24 bits, Dolby Digital 和 DTS

ARC (音頻回傳信道) (僅限 HDMI IN 4)

MHL (與 HDMI IN 1 共用)

視訊 (2D): 1080p (30 Hz), 1080/24p, 1080i (50, 60 Hz), 720p (30, 50, 60 Hz), 720/24p, 576p, 576i, 480p, 480i

視訊 (3D):

並排: 1080/24p, 1080i (50, 60 Hz), 720p (50, 60 Hz)

上下格式: 1080p (30 Hz), 1080/24p, 1080i (50, 60 Hz), 720p (50, 60 Hz)

音訊: 5.1 聲道線性 PCM: 32, 44.1, 48, 88.2, 96, 176.4 和 192 kHz, 16, 20 和 24 bits, Dolby Digital 和 DTS

DIGITAL AUDIO OUT (OPTICAL)

數位光纖插孔 (兩聲道線性 PCM, Dolby Digital 和 DTS)

HDMI 3 AUDIO IN

類比音訊輸入 (立體聲迷你插孔)

AUDIO OUT (立體聲迷你插孔)

耳機、音訊輸出、超低音揚聲器

USB

USB 埠

DC IN 19.5 V

AC 適配器輸入

LAN

10BASE-T/100BASE-TX 接頭 (視網絡的作業環境而定, 連線速度可能不同。不保證本電視的 10BASE-T/100BASE-TX 通訊率和通訊品質。)

其他

選用的配件

觸控板遙控器: RMF-TX100E

壁掛式支架: SU-WL450

無線重低音揚聲器: SWF-BR100

MHL 訊號線: DLC-MC10/DLC-MC20

主動式 3D 眼鏡: TDG-BT500A



作業溫度

0 °C - 40 °C

操作濕度

10% - 80% 相對濕度 (非冷凝)

電源和其他規格

電源需求

用 AC 適配器時為 19.5 V DC

額定: 輸入 220 V - 240 V AC, 50 Hz

螢幕尺寸 (對角測量) (大約)

KDL-50W800C: 50 英寸 / 125.7 厘米

KDL-43W800C: 43 英寸 / 108.0 厘米

顯示解析度

1,920 點 (水平) × 1,080 條線 (垂直)

耗電量

KDL-50W800C: 94 W

KDL-43W800C: 82 W

尺寸 (大約) (寬 × 高 × 深)

包含桌面底座

KDL-50W800C: 1,116 × 691 × 191 毫米

KDL-43W800C: 962 × 602 × 179 毫米

不含桌面底座

KDL-50W800C: 1,116 × 654 × 59 毫米

KDL-43W800C: 962 × 565 × 59 毫米

質量 (大約)

包含桌面底座

KDL-50W800C: 14.6 千克

KDL-43W800C: 11.8 千克

不含桌面底座

KDL-50W800C: 13.7 千克

KDL-43W800C: 10.9 千克

註

- 選購配件的供應視國家 / 區域 / 電視機型號 / 存貨而定。
- 設計與規格可能變更而不事先通知。
- 本電視機採用 MHL 2。

商標資訊

- HDMI 和 HDMI High-Definition Multimedia Interface 專用名詞以及 HDMI 標誌是 HDMI Licensing LLC 在美國和其他國家的商標或註冊商標。
- 本產品經過杜比實驗室的授權而製造。Dolby 和雙 D 記號是杜比實驗室的註冊商標。
- “BRAVIA” 和 BRAVIA 是 Sony Corporation 的商標。
- Gracenote、Gracenote eyeQ、Gracenote VideoID、Gracenote Video Explore、Gracenote 標誌和標誌字型以及 “Powered by Gracenote” 標誌是 Gracenote 在美國和 / 或其他國家的註冊商標或商標。
- Opera® Devices SDK from Opera Software ASA. Copyright 1995-2014 Opera Software ASA. All rights reserved.
- Wi-Fi, Wi-Fi Direct, Miracast 和 Wi-Fi Protected Setup 是 Wi-Fi Alliance 的商標或註冊商標。
- MHL、Mobile High-Definition Link 和 MHL 標誌是 MHL Licensing, LLC 的商標或註冊商標。

- 有關 DTS 專利，請參閱 <http://patents.dts.com>。由 DTS, Inc. 授權製造。DTS、其標誌、& DTS 連同其標誌是註冊商標，而 DTS Digital Surround 是 DTS, Inc. 的商標 © DTS, Inc.。
- Designed with UEI Technology™ Under License from Universal Electronics Inc. Portions © UEI 2000 - 2014
- Bluetooth® 字標和標誌乃 Bluetooth SIG, Inc 所有，Sony Corporation 在授權下使用這些標記。其他的商標和商品名稱屬於其各自的所有者。
- ©2015 RealNetworks, Inc. 專利申請中。版權所有。RealNetworks 標誌是 RealNetworks, Inc 的商標。
- TUXERA 是 Tuxera Inc. 在美國及其他國家 / 地區的註冊商標。

HDMI™
HIGH-DEFINITION MULTIMEDIA INTERFACE

DOLBY®
DIGITAL PLUS

 gracenote.

OPERA™
software

MHL™
Mobile High-Definition Link

 **dts**®
Digital Surround



realnetworks.





Customer Support and Contact:

用戶支援和聯絡:

<http://www.sony-asia.com/support>

<http://www.sony.net/>

©2015 Sony Corporation Printed in Malaysia



* 4 5 6 2 0 5 0 1 1 * (1)

4-562-050-11(1)